



## Common and distinct neural correlates of perceptual and memorial selection

Derek Evan Nee\*, John Jonides

Department of Psychology, University of Michigan, 530 Church Street, Ann Arbor, MI 48109-1043, USA

### ARTICLE INFO

#### Article history:

Received 24 April 2008

Revised 6 January 2009

Accepted 10 January 2009

Available online 21 January 2009

### ABSTRACT

A critical aspect of cognitive control is the ability to select goal-relevant information in the face of competing distraction. A popular account is that common top-down selection processes underlie the ability to select among competing percepts and memories. We test the degree to which selective attention and memorial selection recruit the same neural resources. We demonstrate that both functions elicit largely overlapping networks within the dorsolateral prefrontal cortex (DLPFC), frontal eye fields (FEF), premotor cortex, and superior parietal lobule (SPL). Despite the close commonalities of selective attention and memorial selection, our results demonstrate that the SPL and FEF show preferential involvement in selective attention, whereas left ventrolateral prefrontal cortex (VLPFC) is uniquely associated with memorial selection. Thus, the two sorts of selection are not identical. We show further that variations in shared selection circuits are associated with differences in behavioral performance, suggesting that economy of control is beneficial to performance.

© 2009 Elsevier Inc. All rights reserved.

### Introduction

In order to function efficiently, the cognitive system must choose to represent information that is relevant to current goals. When salient distracting information is present, control processes are elicited to select relevant information and/or de-select irrelevant information. Models of cognitive control posit that regions of prefrontal cortex (PFC) and posterior parietal cortex (PPC) play a critical role in selecting among competing representations (Desimone and Duncan, 1995; Deco and Rolls, 2005; Kastner and Ungerleider, 2000; Miller and Cohen, 2001; Gazzaley and D'Esposito, 2007). Fronto-parietal regions are thought to provide top-down signals that bias the cognitive system to represent only relevant information. Under this framework, fronto-parietal regions are presumed to operate upon several levels of representation including percepts, memories, and responses.

In particular, several proposals suggest that processes of selective attention and working memory are closely linked (Desimone and Duncan, 1995; Kastner and Ungerleider, 2000; Awh and Jonides, 2001; Miller and Cohen, 2001; Deco and Rolls, 2005; Lavie, 2005; Gazzaley and D'Esposito, 2007). That is, the same prefrontal and parietal regions involved in maintaining an outward focus on relevant stimuli may also be recruited to maintain an inward focus on relevant thoughts. These ideas are bolstered by demonstrations that maintaining information in working memory causes decrements in the ability to filter out distracting perceptual information (de Fockert et al., 2001; Lavie et al., 2004; Lavie, 2005), consistent with the idea that working memory

and selective attention draw upon the same resources. Furthering the notion that selective attention and working memory are interrelated, subjects who have relatively large working memory spans tend to perform better on selective attention tasks than subjects with relatively low spans (Engle et al., 1999; Kane et al., 2001). Research with nonhuman primates has shown that both selective attention and working memory produce similar modulations of inferior temporal regions thought to maintain object representations (Chelazzi et al., 1993, 1998). These modulations are presumed to originate from frontal and parietal regions (Fuster et al., 1985). Finally, lesions of the PFC cause high distractibility, impairing both attention (Heilman and Valenstein, 1972; Damasio et al., 1980) and working memory (Mishkin, 1957; D'Esposito and Postle, 1999); similarly, lesions of parietal cortex cause attentional deficits in processing of external stimuli and internal memories (Bisiach and Luzzatti, 1978; Bisiach et al., 1979).

Drawing upon hypothesized commonalities, several studies have explored overlapping neural correlates of attention and memory within the same subjects (Labar et al., 1999; Pollmann and von Cramon, 2000; Corbetta et al., 2002; Nobre et al., 2004; Mayer et al., 2007). These studies have all documented overlapping activations for attention and working memory in the frontal eye fields (FEF), premotor cortex, and PPC most often in the intraparietal sulcus (IPS) and superior parietal lobule (SPL). The large amount of overlap suggests that the same processes that support attention to the outside world also direct attention internally to memorial representations (Nobre et al., 2004; Lepsien and Nobre, 2006). Notably absent from these studies, however, are overlapping activations in more anterior regions of PFC (anterior lateral PFC) presumed to be involved in cognitive control, such as dorsolateral prefrontal cortex (DLPFC) in Brodmann Areas (BA) 9 and 46, and ventrolateral prefrontal cortex

\* Corresponding author.

E-mail address: [dnee@umich.edu](mailto:dnee@umich.edu) (D.E. Nee).

(VLPFC) in BA 44 and 45 (Smith and Jonides, 1999). In several of these studies, regions in anterior lateral PFC were involved in memory, but not attention (Labar et al., 1999; Pollmann and von Cramon, 2000; Nobre et al., 2004; Mayer et al., 2007).

One reason for this dissociation may have to do with demands elicited by the attention tasks. In the aforementioned studies, the tasks used to examine attention investigated processes involved in either maintaining attention on a particular location or searching for a target in a visual array. Such tasks place a relatively low demand on selective attention processes that filter out visual distraction. By contrast, selective attention tasks that require the filtering of distraction are known to robustly recruit regions of anterior lateral PFC (Nee et al., 2007b). A similar filtering function has been proposed to protect working memory representations, especially when demands on control are increased (D'Esposito and Postle, 1999; Smith and Jonides, 1999; Jonides et al., 2005; Ranganath, 2006). Therefore, there may be similar anterior lateral PFC recruitment when selection processes need to maintain relevant information in the face of irrelevant distracting information.

Despite hypothesized similarities, we are unaware of any study that has directly compared processes of selective attention and working memory in the same subjects. Direct comparisons are critical for understanding the extent to which selective attention and working memory are truly similar functions. For instance, although it is well-established that there is activation in PFC for both selective attention and working memory tasks, it is less well-established that the same subregions of the PFC are responsible for the two processes. Investigating this matter can provide critical data for understanding the functions of different regions of PFC. Similarly, research into PPC has suggested differentiable roles for subregions of the PPC in attention (Corbetta and Shulman, 2002; Yantis and Serences, 2003) and memory (Wagner et al., 2005), and understanding which of these subregions contribute commonly or uniquely to attention and memory would further our understanding of computations in the PPC.

In addition to investigating neural overlap, it is also critical to relate neural data to behavioral measures in order to directly demonstrate relationships between brain and behavior. That is, even if a region appears to be involved in both selective attention and working memory, that region may play a very different role in each (Rowe et al., 2005). Relating brain data to behavioral data may uncover these relationships and further our understanding of the neural regions subserving selective attention and working memory.

Here, we compared selection processes operating upon percepts and memories. To do so, we adapted an item-recognition paradigm that forced subjects either to filter out irrelevant perceptual information or to expel irrelevant memorial information from working memory. Perceptual and memorial selection were assessed in the same subjects to allow for careful comparisons between these processes. If top-down processes of selection are common between perceptual and memorial selection, we would expect to see similar recruitment of frontal and parietal control regions. However, if distinct selection functions operate in perception and memory, we should see regions that are engaged by one form of selection but not the other. For all analyses, we examined the relation between neural activation and behavioral assays of selection in order to provide strong evidence that neural regions were closely related to behavioral phenomena of interest.

Subjects alternated between runs of the perceptual selection task and memorial selection task (Fig. 1; see Materials and methods for complete details). In both tasks, subjects committed a set of words (target set) to memory and responded to recognition probes that queried the target set several seconds later. In the perceptual selection task, subjects encoded three relevant words from a visual display while filtering out three distracting words (word-distraction), three distracting strings of pound signs (pound-distraction), or no distraction (no-distraction). Relevant words were printed in one color (blue or teal), with irrelevant words printed in an alternate color (blue if the relevant words were teal; teal if the relevant words were

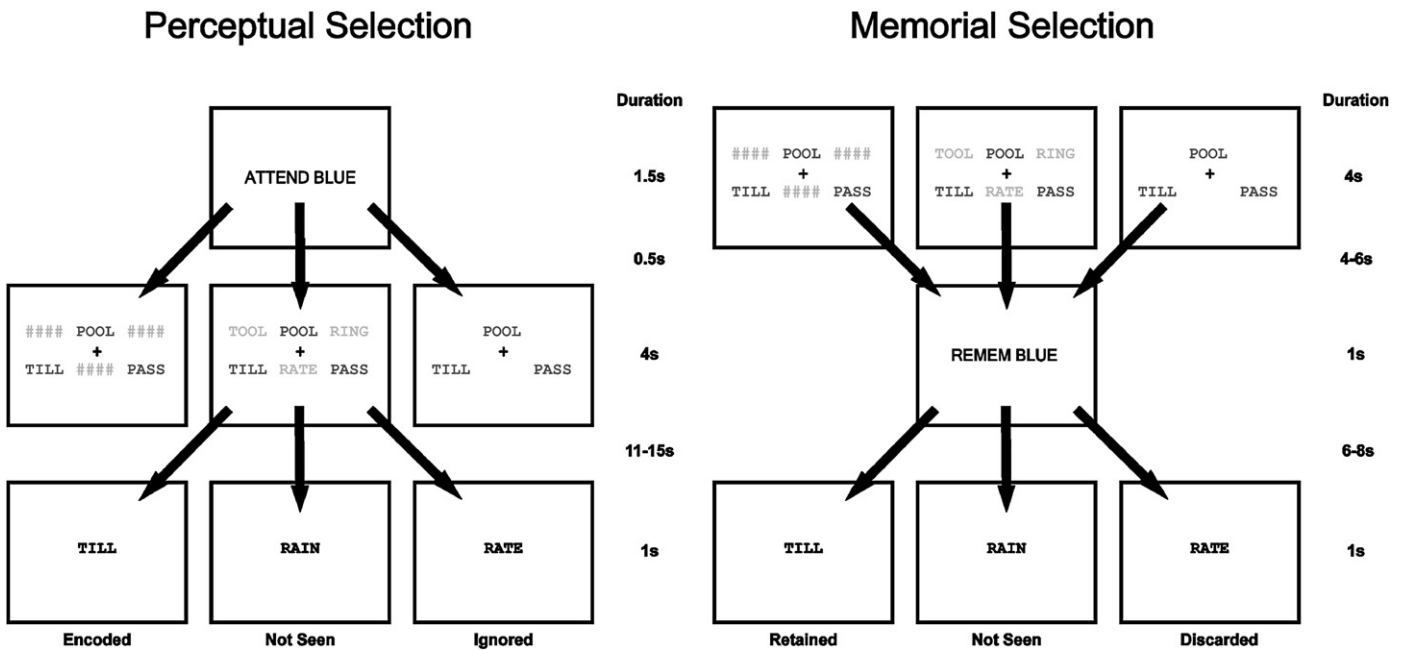

**Fig. 1.** Experimental protocol. In the perceptual selection task (left), subjects committed a set of three target words to memory while filtering out distracting words (word-distraction), pound signs (pound-distraction), or with no distraction present (no-distraction). In the memorial selection task (right), subjects committed all available words to memory and were later told to either update memory to reduce their memory load to three (update), or rehearse the three words already in memory (rehearse). At the end of each trial, subjects were probed to verify that selection was done appropriately. Probes queried words that were supposed to be in memory (Encoded/Retained: *positive probes*), words that had not been seen recently (Not Seen: *control probes*), and words that were either ignored (Ignore: *ignore probes*) or removed from memory (Discarded: *forget probes*). Neural activation of interest was locked to the onset of the target display for the perceptual selection task, and to the onset of the memory cue in the memorial selection task. Words printed in light gray appeared in teal, and words printed in dark gray appeared in blue. All other characters were presented in black. Both attention and memory cues appeared on all trials. Only attention cues are depicted in the perceptual selection task here, and only memory cues are depicted in the memorial selection task here for simplicity.

blue). A cue on each trial alerted subjects which words they would have to encode. Subjects were instructed to read the three relevant words subvocally and make a keypress after doing so, providing a behavioral measure of the duration and difficulty of perceptual selection processes.

In the memorial selection task, subjects saw the same three types of displays, except that they were instructed to encode and remember all printed words. Hence, subjects encoded either six or three words. Several seconds after encoding, subjects received a cue that told them to update memory if they had encoded six words (update) or subvocally rehearse if they had encoded three words (rehearse). Update cues informed subjects to retain three words in memory and discard the other three words from memory. Update cues were phrased in a manner that instructed subjects either to remember words of a given color (e.g. “REMEM TEAL”, remember cue) or to forget words of a given color (e.g. “FORGET BLUE”, forget cue). Both remember and forget cues left subjects with three words in memory and were functionally equivalent. On update trials, subjects were instructed to update memory and then subvocally rehearse the three relevant words once and make a keypress after doing so. On rehearse trials, subjects were instructed to rehearse the three words in memory once and make a keypress after doing so. Contrasting keypress latencies following update and rehearse trials provided a behavioral measure of memorial selection.

Successful selection was examined behaviorally by responses to recognition probes (Nee and Jonides, 2008). Recognition probes queried relevant words (positive probes), words that had not appeared and therefore required a negative response (control probes), or words that had been ignored (ignore probes) or discarded from memory (forget probes). Both ignore and forget probes demanded a negative response. Hence, comparing responses to ignore and forget probes with responses to control probes provides a measure of successful selection. In previous reports, forget probes have induced slowed and less accurate responses compared to control probes, presumably due to effects of proactive interference (Zhang et al., 2003; Jonides and Nee, 2006; Nee and Jonides, 2008). Increased effects of proactive interference are likely to be related to poorer memorial selection. Previous research has also demonstrated slowed responses to ignore probes compared to control probes (Nee and Jonides, 2008), putatively due to effects of negative priming (May et al., 1995; Fox, 1995; Tipper, 2001).

## Materials and methods

### Participants

Eighteen right-handed adults (8 female; ages 19–25) participated in this study. All subjects had normal or corrected-to-normal vision and had no reported illnesses. Subjects were compensated \$20/hr plus a bonus for fast and accurate performance. Two runs from one subject were excluded from analysis due to her difficulty with task instructions, and one run was excluded from another subject due to problems with the visual presentation equipment.

### Materials and procedure

Words were drawn from a list of 100 four-letter nouns. Words were drawn randomly for each trial with the exception that words could not have been presented in the previous 2 trials in order to control for potential effects of proactive interference. All responses were recorded on a 10-button response unit that accompanied the IFIS 9.0 system (MRI Devices Corp., Latham, NY) with one button for each finger. Stimuli were presented via a projector at the back of the scanner, reflected off a mirror placed above the head of the subject. Experimental tasks were presented using E-Prime software (Psychology Software Tools, Inc., Pittsburgh, PA).

During the perceptual selection task each trial began with a red fixation cross presented for 1 s to alert the subject that the trial was beginning. Thereafter, an attention cue (“ATTEND BLUE”, “ATTEND TEAL”, “IGNORE BLUE”, or “IGNORE TEAL”) was presented for 1.5 s that informed the subject of the color of the relevant stimuli. On half of the trials, the words printed in blue were made relevant and the words printed in teal were made irrelevant; the reverse was true for the other half of the trials. Three-fourths of the cues involved “attend” instructions, with the other one-fourth involving “ignore” instructions. We collapsed across different cue instructions and “ignore” instructions were used only to parallel the memorial selection task. “Attend” and “ignore” instructions did not produce appreciably different results.<sup>1</sup>

The attention cue was followed by 0.5 s of fixation, followed by the target display. The target display consisted of three words presented in the relevant color in a “V” or upside-down “V” shape. On one-half of the trials, three distractor words (word-distraction) were presented in the alternate color (blue if the relevant words were teal, teal if the relevant words were blue). On one-fourth of the trials, a string of four pound signs was used in place of distracting words (pound-distraction) and on the other one-fourth of the trials, no distracting information appeared (no-distraction). All of the stimuli considered together subtended approximately 9.7° of visual angle horizontally, and approximately 3.5° vertically. Each word or string of pound signs subtended approximately 2.6° of visual angle horizontally, and 0.88° vertically. Stimuli were separated by 0.88° horizontally, and 1.76° vertically.

Subjects were instructed to read the three relevant words subvocally once and make a left thumb press after doing so. Subjects were told to maintain the relevant words in memory. The target display was presented for 4 s, and subjects were instructed to stare at the fixation cross and to continue to attend to relevant words and ignore irrelevant information when they had completed encoding the relevant words.

A fixation interval of 4 to 6 s followed the target display, varied in equal steps of 1 s. Thereafter, a cue (memory cue) appeared instructing subjects to rehearse the relevant words once and make a left thumb press after doing so. The cue stated “REMEM BLUE” or “REMEM TEAL” (always the relevant color), or “REMEM ALL” and paralleled the memorial selection task. All memory cues in the perceptual selection task were functionally equivalent in that they all required a simple rehearsal of the three words in memory. The cue was followed by a 6 to 8-second fixation interval, varied in equal steps of 1 s. Finally, a recognition probe was presented for 1 s, followed by an inter-trial interval of 3 to 5 s, varied in equal steps of 1 s. Subjects responded with a right index press if the probe matched one of the three words held in memory (positive probe), and they made a left index press otherwise (negative probe). One-half of the probes were positive probes and one-half were negative probes. Three-quarters of the negative probes were words that had not appeared for the last 2 trials (control probes)

<sup>1</sup> Behavioral keypress latencies following each of these cue conditions were indistinguishable (“attend” versus “ignore” instructions with word-distraction,  $p > 0.3$ ). Furthermore, we compared activation to “attend” versus “ignore” instructions during selection in the word-distraction condition. This analysis was restricted to regions identified by the perceptual selection contrast at  $p < 0.01$ , and the contrast was thresholded at  $p < 0.001$  with a 20 contiguous voxel criterion. Two parietal regions emerged from this analysis, one in the left intraparietal sulcus and a second in the left precuneus. To examine these patterns further, we separately examined selected-related activation following “attend” and “ignore” instructions in these regions. The intraparietal sulcus, although demonstrating stronger activation during selection following “ignore” instructions, was also activated strongly during selection following “attend” instructions ( $t(17) = 4.95$ ,  $p < 0.001$ ). Only in the precuneus was there selection-related activation following “ignore” instructions ( $t(17) = 3.56$ ,  $p < 0.005$ ), but not following “attend” instructions ( $p > 0.9$ ). Since this 151 voxel cluster was meager in comparison to the sizeable clusters activated in the perceptual selection contrast as a whole, we felt that collapsing across “attend” and “ignore” instructions was warranted.

and one-quarter were probes that matched a word that had appeared as a distractor on the target display (ignore probes). The asymmetry of the number of ignore probes is due to the fact that ignore probes could only follow the word-distraction condition. Within the word-distraction condition, control and ignore probes were equally distributed. All combinations of cue and probe were randomly intermixed.

The memorial selection task was nearly identical to the perceptual selection task and we describe only the differences here. In the memorial selection task, the attention cue stated either “ATTEND BLUE”, “ATTEND TEAL”, or “ATTEND ALL”. Following “ATTEND BLUE” and “ATTEND TEAL” instructions, three words were presented in the relevant color, and the three other positions were either unfilled or filled with strings of pound signs so that no competing word stimuli were present (initial memory load three). Following “ATTEND ALL” instructions, six words were presented, three printed in blue and three printed in teal, and subjects were instructed to encode and remember all six words (initial memory load six). After encoding relevant words, subjects made a left thumb press, as in the perceptual selection task.

In the memorial selection task, memory cues told subjects to either remember words of a relevant color (e.g. “REMEM BLUE”; remember cue) or forget words of an irrelevant color (e.g. “FORGET TEAL”; forget cue). The classification of cue depended upon the information held in memory. Rehearse cues followed initial memory loads of three and always instructed subjects to remember words of the relevant color. Subjects were instructed to rehearse the three words in memory once and make a left thumb press after doing so. Update cues followed initial memory loads of six and instructed subjects to select the three relevant words from their memory set, rehearse those three words, and make a left thumb press after doing so. Hence, the critical difference between rehearse and update cues was the need to perform memorial selection to the latter. Half of the update cues instructed subjects to remember words of the relevant color, and the other half instructed subjects to forget words of the irrelevant color. Both cues were functionally equivalent in that they left subjects with the three relevant words in memory. However, we hypothesized that forget cues placed a greater demand on memorial selection processes due to the stimulus–memory incompatibility inherent in these cues. In other words, forget cues lead subjects to the irrelevant information, much as stimulus–response incompatible stimuli lead subjects to an inappropriate response. Just as stimulus–response incompatibilities place larger demands on response–selection processes (Fitts and Seeger, 1953), we hypothesized that stimulus–memory incompatibilities would place greater demands on memorial selection processes (see also Zhang et al., 2008).

As in the perceptual selection task, subjects responded to positive and control probes in the memorial selection task. In lieu of ignore probes, one-quarter of the negative probes were words that matched a word that subjects had been instructed not to retain in memory (forget probes).

Subjects alternated between runs of the perceptual selection task and memorial selection task, with order counterbalanced between subjects. For each task, subjects performed four runs of 18 trials each, for a total of 72 trials. The day prior to scanning, subjects performed two runs of each task with accuracy and latency feedback. On the day of scanning, subjects performed an additional run of practice for each task also with feedback. Feedback was not given during scanning, but average accuracy and reaction times were presented during rest breaks between scans so that subjects could monitor their performance.

#### *Image acquisition and preprocessing*

Images were acquired on a GE Signa 3-T scanner equipped with a standard quadrature head coil. Head movement was minimized using

foam padding and a cloth restraint strapped across participants' foreheads.

Functional T2\*-weighted images were acquired using a spiral sequence with 40 contiguous slices with 3.44×3.44×3 mm voxels (repetition time, or TR=2000 ms; echo time, or TE=30 ms; flip angle=90°; field of view, or FOV=22 mm<sup>2</sup>). A T1-weighted gradient-echo anatomical overlay was acquired using the same FOV and slices (TR=250 ms, TE=5.7 ms, flip angle=90°). Additionally, a 124-slice high-resolution T1-weighted anatomical image was collected using spoiled-gradient-recalled acquisition (SPGR) in steady-state imaging (TR=9 ms, TE=1.8 ms, flip angle=15°, FOV=25–26 mm<sup>2</sup>, slice thickness=1.2 mm).

Each SPGR anatomical image was corrected for signal inhomogeneity and skull-stripped using FSL's Brain Extraction Tool (Smith et al., 2004). These images were then normalized to the Montreal Neurological Institute (MNI) template using SPM2 (Wellcome Department of Cognitive Neurology, London). Functional images were corrected for differences in slice timing using 4-point sinc interpolation (Oppenheim et al., 1999) and were corrected for head movement using MCFLIRT (Jenkinson et al., 2002). To reduce the impact of spike artifacts, we winsorized functional images on a voxel-by-voxel basis so that no voxel had a signal greater than 3.5 standard deviations from the mean of the run (Lazar et al., 2001). Spatial normalization transformations and 8-mm full-width/half-maximum isotropic Gaussian smoothing were applied to all functional images prior to analysis using SPM2. All analyses included a temporal high-pass filter (128 s), and each image was scaled to have a global mean intensity of 100.

#### *Image analysis*

Analyses were conducted using the General Linear Model implemented in SPM2. Predictors of interest were locked to the onsets of the target display and memory cue and were convolved with a canonical hemodynamic response function provided by SPM2. Additional predictors were used to model the probe, which were not involved in the present analyses. To account for artifacts produced by head motion, we calculated linear, quadratic, differential, and quadratic differential motion regressors from the realignment parameters and included these regressors in the model (Lund et al., 2005). Trials in which subjects failed to make a keypress to the target set or rehearsal cue and/or trials in which subjects responded incorrectly to the recognition probe were excluded and left un-modeled (less than 9% of the trials). Although model fits may be improved by explicitly modeling error trials and excluding them from contrasts of interest, this method simplifies the model and does not add systematic bias that could explain any of the obtained results.

For perceptual selection, separate regressors were calculated for word-distraction, pound-distraction, and no-distraction.<sup>2</sup> Selection-related activation for word-distraction was considered high selection, and pound-distraction and no-distraction were collapsed into low selection. For memorial selection, separate regressors were calculated for update cues (high selection) and rehearse cues (low selection). Update cues were also divided into remember cues and forget cues for follow-up analyses. Memory cues in the perceptual selection task and attention cues in the memorial selection task were also modeled and treated as predictors of non-interest.

For both perceptual and memorial selection, whole-brain analyses contrasted high and low selection and were thresholded at  $p < 0.001$  with a cluster extent of at least 20 suprathreshold voxels (Forman et

<sup>2</sup> Notably, this contrast confounds number of presented items (six in word-distraction contrasted with ~4.5 when pound-distraction (six items) and no-distraction (three items) are averaged together). However, contrasting word-distraction with pound-distraction, which controls for the number of presented items, produces clusters overlapping all non-occipital sites reported. Therefore, selection regions of interest do not appear to be affected by this potential confound and only early perceptual regions appear to reflect these presentation differences.



al., 1995; Poline et al., 1997). This threshold required a minimum  $t$ -statistic of 3.65, which was similar to the minimum  $t$ -statistic required by a multiple-comparisons corrected threshold for the perceptual selection contrast (false discovery rate (FDR) minimum  $t$ -statistic of 3.87 for  $p < 0.05$ ), and more conservative than the same threshold for the memorial selection contrast (FDR minimum  $t$ -statistic of 2.97 for  $p < 0.05$ ). We used an uncorrected threshold to hold the minimum  $t$ -statistic constant between contrasts.

For the conjunction analysis, perceptual and memorial selection contrasts were thresholded at  $p < 0.01$ , producing a conjoint threshold of  $p < 0.0001$ . Once again, we used a minimum cluster extent of 20 voxels.

We identified unique regions by a three-part criterion: 1) significant activation for one contrast at  $p < 0.001$ ; 2) significantly more activation for one contrast than the other at  $p < 0.01$ ; 3) no significant activation in the other contrast at  $p < 0.01$ . Once again, we used a minimum cluster extent of 20 voxels.

The examination of forget versus remember cues was restricted to regions significant in the memorial selection contrast at  $p < 0.01$ . Within these regions, we looked for voxels significantly more active for forget cues versus remember cues at  $p < 0.05$ , with a minimum cluster extent of 20 voxels. The reduced threshold was used due to the reduction in power of considering only half of the memorial selection trials.

Correlations between neural activation and behavior were restricted to voxels significant by the criterion above for each contrast of interest. Correlations are reported only if they were significant at  $p < 0.05$ , and only if they were significant after robust regression to reduce the impact of outliers.

## Results

### Behavioral results

#### Accuracy data

We used a modified item-recognition task (Fig. 1) to examine processes of perceptual and memorial selection. All trials in which subjects failed to make a keypress after encoding or after updating memory were excluded from behavioral analysis (less than 3% of the trials).

First, we assessed accuracy to recognition probes. Accuracy was high overall (>94%), and significantly higher on the perceptual selection task (96.0%) than the memorial selection task (92.3%,  $t(17)=2.8$ ,  $p < 0.05$ ). The high accuracies demonstrate that subjects performed the tasks appropriately. Follow up tests considered each task separately. In the memorial selection task, accuracy differed significantly by probe type (positive, control, forget; ( $F(2,34)=6.3$ ,  $p < 0.01$ ). This was driven largely by reduced accuracy to forget probes (83.3%), which was significantly lower than accuracy to control probes (94.7%,  $t(17)=2.4$ ,  $p < 0.05$ ) and positive probes (94.5%,  $t(17)=2.9$ ,  $p < 0.05$ ). This is to be expected due to the high degree of proactive interference associated with forget probes (Jonides and Nee, 2006). There was also a significant effect of initial memory load with higher accuracy to low initial load (96.7%) than high initial load (88%,  $t(17)=3.6$ ,  $p < 0.01$ ). Although memory load was equivalent by the time subjects made recognition decisions (i.e., a load of three words), these load effects on accuracy may reflect differences during retention before the memory update, or difficulties with memory updating. No factors had an effect on accuracy in the perceptual selection task ( $F(2,34) < 1$  for all tests). For all subsequent analyses with latency data, trials in which subjects made an incorrect response to the recognition probe were excluded (<6% of the trials).

#### Behavioral measures of memorial and perceptual selection

After encoding the target set (perceptual selection) or after updating and/or rehearsing the contents of working memory (memorial

selection), subjects made a keypress to denote that selection processes were complete. These keypress data were entered into a 2-way ANOVA, with factors of selection demands (high or low) and selection type (perceptual or memorial) as factors. There were significant main effects of selection demands ( $F(1,17)=59.25$ ,  $p < 0.001$ ) and selection type ( $F(1,17)=7.19$ ,  $p < 0.05$ ). However, there was no interaction between selection demands and type ( $F(1,17) < 1$ ). These results indicated that high selection demands led to slower keypress latencies than low selection demands, and that subjects took longer to perform perceptual selection than memorial selection. The lack of interaction between selection demands and type suggests that selection demands were equivalently increased for high versus low selection in both perceptual and memorial selection tasks.

Follow up analyses examined keypress latencies for memorial selection alone. A planned  $t$ -test demonstrated that keypress latencies following update instructions were significantly longer than keypress latencies following rehearsal instructions (1211 ms versus 919 ms, mean difference=292 ms,  $t(17)=5.24$ ,  $p < 0.001$ ). This difference provides an assay of the time it takes to perform the memory update function. Next, we examined whether updates following forget cues were significantly different from updates following remember cues. We predicted that forget cues would require increased memorial selection demands because forget cues lead the subject toward the irrelevant information, whereas remember cues lead the subject toward the relevant information. As such, forget cues have a stimulus–memory incompatibility that may mimic stimulus–response incompatibility effects (Fitts and Seeger, 1953). In line with this prediction, keypress latencies following forget cues were slowed relative to remember cues (mean difference=51 ms,  $t(17)=1.81$ ,  $p < 0.05$ , one-tailed). These results suggest that memorial selection demands were enhanced for forget cues relative to remember cues (see Zhang et al., 2008 for similar results). For perceptual selection, word-distraction led to slower keypress latencies than pound-distraction (1430 ms versus 1176 ms,  $t(17)=6.6$ ,  $p < 0.001$ ) and no-distraction (1430 ms versus 1183 ms,  $t(17)=4.68$ ,  $p < 0.001$ ), but pound-distraction and no-distraction did not differ ( $t(17)=0.22$ ,  $p > 0.8$ ).

#### Recognition probe data

Next, we examined reaction times to recognition probes. Reaction times were slower during the memorial selection task (723 ms) compared to the perceptual selection task (680 ms,  $t(17)=5.4$ ,  $p < 0.001$ ). Follow up tests considered each task separately. In the memorial selection task, there was a significant effect of probe type on recognition latency ( $F(2,34)=41.3$ ,  $p < 0.001$ ). This was largely driven by increased reaction times to forget probes (852 ms) compared to control probes (700 ms,  $t(17)=5.9$ ,  $p < 0.001$ ) and positive probes (661 ms,  $t(17)=7.9$ ,  $p < 0.001$ ). Once again, these differences are to be expected due to the high degree of proactive interference associated with forget probes (Jonides and Nee, 2006). There was also a significant effect of initial memory load with slower responses following initially high loads (752 ms) than low loads (669 ms,  $t(17)=6.8$ ,  $p < 0.001$ ). Once again, although load was equivalent across all conditions by the time subjects made recognition decisions, increased latencies for initially high memory loads may reflect difficulties encountered during earlier processing. Latency data to recognition probes in the ignore task demonstrated slowed latencies to ignore probes compared to control probes ( $t(17)=1.76$ ,  $p < 0.05$ , one-tailed, 32 ms), consistent with previous findings (Nee and Jonides, 2008).

#### Behavioral summary

To summarize, we found anticipated behavioral effects of selection demands during perceptual and memorial selection. Moreover, selection effects were carried out to subsequent memory probes, giving an assay of the success (or lack thereof) of selection. High

interference to forget probes demonstrated a large degree of proactive interference that carried over to recognition decisions, suggesting that memory updating processes failed to completely discard irrelevant memorial information (Jonides and Nee, 2006; Nee and Jonides, 2008).

### Neural results

#### Perceptual selection

Activation increases corresponding to increased demands on perceptual selection recruited several frontal regions including bilateral FEF, premotor cortex, DLPFC, and the anterior cingulate and surrounding medial prefrontal cortex (Table S1; Fig. 2). Hence, not only were posterior regions of PFC, such as the FEF and premotor cortex, involved in perceptual selection, but also more anterior regions in left (BA 9/46) and right DLPFC (BA 10). In addition, activation increases to selective attention demands were found in PPC, mostly in bilateral SPL, but also including some portions of the IPS, right inferior parietal lobule, and right temporo-parietal junction.

#### Memorial selection

Regions involved in memorial selection largely included regions involved in perceptual selection, but with notable additions in bilateral IPS and VLPFC (Table S1; Fig. 2). VLPFC activation was particularly pronounced in the left hemisphere, including all of pars triangularis (BA 45), as well as portions of more posterior left inferior frontal gyrus (pars opercularis, BA 44), and more anterior in pars orbitalis (BA 47). There was also extensive recruitment of anterior portions of the left middle frontal gyrus in BA 10.

#### Conjunction

Confirming the hypothesis that perceptual and memorial selection are related processes, a conjunction analysis produced largely overlapping activations in frontal and parietal regions (Fig. 2; Table S2). Frontal overlap was most prominent in posterior regions of PFC including bilateral FEF, premotor cortex, and the anterior cingulate and surrounding medial prefrontal cortex. However, in contrast to previous reports (Labar et al., 1999; Pollmann and von Cramon, 2000; Nobre et al., 2004; Mayer et al., 2007), both perceptual and memorial selection recruited more anterior regions of PFC in DLPFC. That regions of DLPFC were common to both perceptual and memorial selection is consistent with the idea that similar PFC top-down control is exerted across both domains (Desimone and Duncan, 1995; Kastner and Ungerleider, 2000; Miller and Cohen, 2001; Deco and Rolls, 2005; Gazzaley and D'Esposito, 2007;).

Interestingly, parietal overlap was almost exclusively restricted to the SPL, sparing most portions of the IPS. This result is in stark contrast with previous reports that attention and memory produce common activations in the IPS (Labar et al., 1999; Pollmann and von Cramon, 2000; Nobre et al., 2004; Mayer et al., 2007). It is unlikely that the lack of common IPS activation is due to lack of power since over 8000 common voxels were uncovered in our conjunction analysis. We return to the lack of IPS involvement in the discussion.

#### Unique perceptual selection regions

Although there was clearly a good deal of overlap between perceptual and memorial selection, we were interested in whether any regions were uniquely recruited for perceptual selection. To examine this, we searched for regions that demonstrated significant

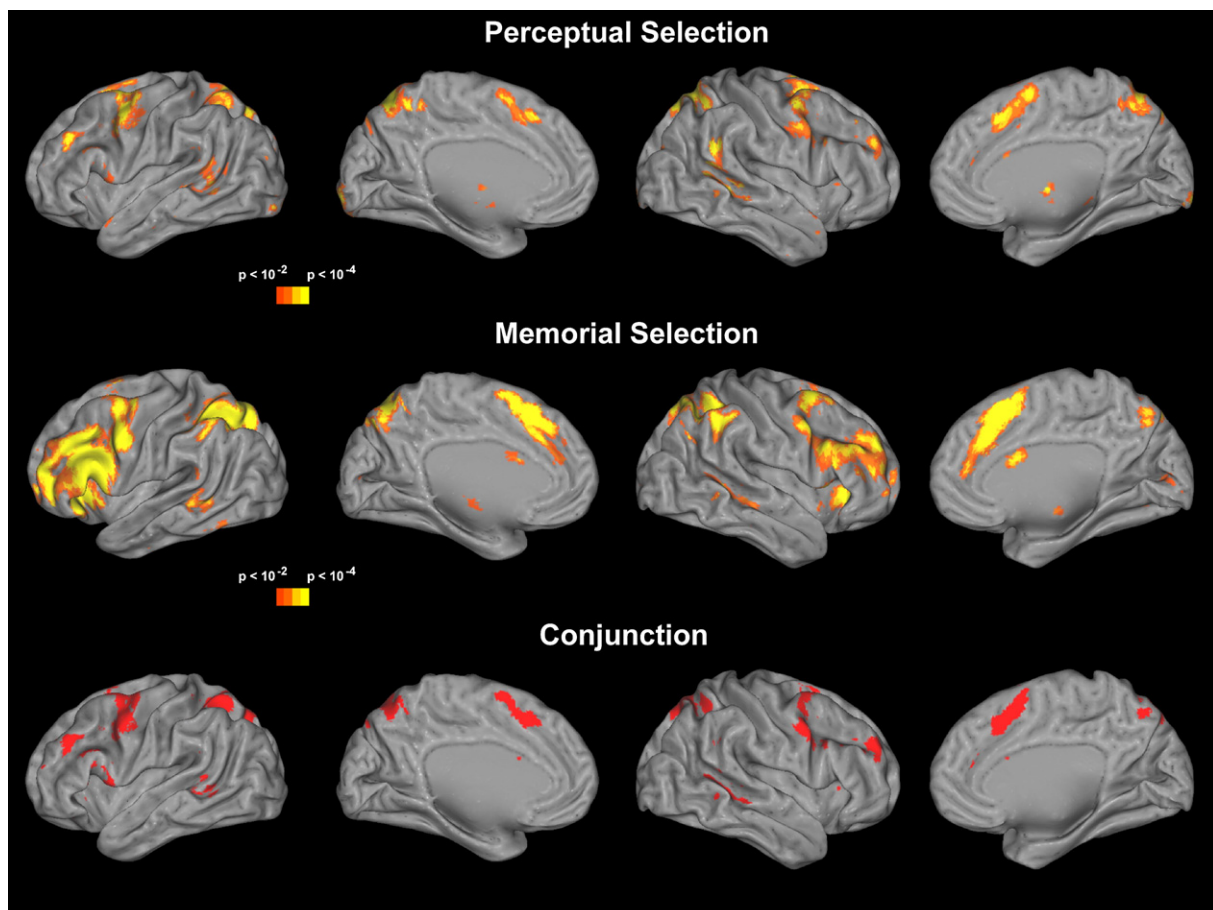

**Fig. 2.** Whole-brain neural results. Regions active for high versus low selection in the perceptual selection task (top), memory selection task (middle), and the conjunction of both tasks (bottom).

activation for perceptual selection, significantly more activation for perceptual selection than memorial selection, and no significant activation for memorial selection (see [Materials and methods](#)).

Fronto-parietal regions unique to perceptual selection were found most prominently in bilateral SPL, and right FEF ([Fig. 3](#); [Table S4](#)). These regions were adjacent to regions found in the conjunction analysis and suggest that the SPL and FEF, although common to both perceptual and memorial selection, may be more strongly related to perceptual selection. Regions unique to perceptual selection were also found in the right temporo-parietal junction, which has been linked to functions of attentional orienting ([Corbetta et al., 2002](#); [Corbetta and Shulman, 2002](#)).

#### Unique memorial selection regions

We also assessed regions unique to memorial selection by searching for regions that demonstrated significant activation for memorial selection, significantly more activation for memorial selection than perceptual selection, and no significant activation for perceptual selection (see [Materials and methods](#)).

Fronto-parietal regions unique to memorial selection included large portions of bilateral VLPFC, most prominently on the left ([Fig. 3](#); [Table S4](#)). In the left hemisphere, unique activation due to memorial selection was largely localized to pars triangularis of the left inferior frontal gyrus (BA 45), but also included posterior (BA 44) and anterior (BA 47) portions of the inferior frontal gyrus, and spread further anterior into BA 10. Activation increases also stretched dorsally into the inferior frontal sulcus and inferior portions of the middle frontal gyrus (BA 9/46). A similar, but less pronounced pattern was observed in the right hemisphere, including BA 45 and 13 ventrally, 9/46 dorsally, and BA 10 in the anterior portions of the middle frontal gyrus. Regions of the medial prefrontal cortex including the anterior cingulate also showed a preferential pattern for memorial selection.

The horizontal portion of bilateral IPS was also uniquely involved in memorial selection. These activations spread inferiorly to the most dorsal aspects of the inferior parietal lobule. This result is surprising given that the IPS has been found to be a region common to both attention and memory in previous reports ([Labar et al., 1999](#);

[Pollmann and von Cramon, 2000](#); [Nobre et al., 2004](#); [Mayer et al., 2007](#)). Additionally, unique activation due to memorial selection was observed in the medial portions of parietal cortex in the precuneus.

#### Memorial selection specificity

Our memorial selection contrasts have thus far assessed memory updating processes that reduce a memory load of six down to three, compared to simple rehearsal of three items. Whereas we are primarily interested in the processes that select memorial information, our results may potentially be contaminated by differences in load before the memory cue. To address this concern, we compared selection-related activation to forget cues contrasted with remember cues. In both cases, subjects began with a memory load of six and used selection processes to reduce the load down to three. However, our behavioral data suggest that selection is more difficult to forget cues. Just as stimulus–response incompatibility calls for increased processes of response selection ([Fitts and Seeger, 1953](#)), forget cues may elicit stimulus–memory incompatibilities that call for increased memorial selection. Therefore, we hypothesized that contrasting forget and remember cues would more clearly isolate memorial selection processes.

To investigate memorial selection processes with more specificity, we therefore looked for regions that showed increased activation to forget cues compared to remember cues, restricted to regions that were reliable in our original memorial selection contrast. This analysis produced a very similar network of regions including bilateral VLPFC, DLPFC, medial PFC including the anterior cingulate, FEF, premotor cortex, and bilateral IPS and SPL. Hence, our memorial selection results are unlikely to be due to memory load, and seem to instead reflect memorial selection processes.

To bolster this claim, we looked for regions that correlated with behavioral selection latency differences between forget and remember cues, restricting ourselves to the regions found active above. Confirming their role in memorial selection, left lateral PFC (MNI center  $-46\ 20\ 26$ ; BA 46/9/45; 166 voxels;  $r=0.52$ ,  $p<0.05$ ), left IPS (MNI center  $-34\ -64\ 52$ ; BA 7/40; 164 voxels;  $r=0.63$ ,  $p<0.01$ ), and left medial PFC (MNI center  $-2\ 30\ 46$ ; BA 8; 139 voxels;  $r=0.64$ ,  $r<0.01$ ) all demonstrated a correlation between neural activation and behavioral performance ([Fig. 4](#)). Not only did these regions show greater activation for forget cues compared to remember cues, all of these regions also demonstrated significantly more activation for remember cues than rehearse cues (all  $t(17)>4$ ,  $p<0.001$ ). Hence, these regions varied parametrically with memorial selection demands, rather than being unique to forget cues.

#### Left ventrolateral prefrontal cortex and proactive interference

Left VLPFC, particularly in BA 45, has been shown to have a strong engagement in the resolution of proactive interference ([Jonides et al., 1998](#); [D'Esposito et al., 1999](#); [Thompson-Schill et al., 2002](#); [Nelson et al., 2003](#); [Zhang et al., 2003](#); [Postle and Brush, 2004](#); [Postle et al., 2004](#); [Badre and Wagner, 2005](#); [Jonides and Nee, 2006](#); [Nee et al., 2007a](#); [Nee and Jonides, 2008](#)). Such demonstrations have generally relied on item-recognition tasks that probe highly familiar but irrelevant information. Recent hypotheses about such effects have relied on the idea that left VLPFC may be involved in selecting among memorial representations, placing items into appropriate contexts in order to guide recognition performance ([Badre and Wagner, 2005](#); [Jonides and Nee, 2006](#); [Nee et al., 2007a](#)). [Braver et al. \(2007\)](#) have suggested that these selection operations need not be restricted to recognition decisions, but rather, subjects may act in a proactive manner to reduce interference by performing appropriate selection during delay intervals before a recognition probe. In our task, subjects are required to perform such a selection in that the update cue forces subjects to discard irrelevant information and rehearse relevant information. Therefore, left VLPFC activation during memorial selection may protect the cognitive system from later proactive

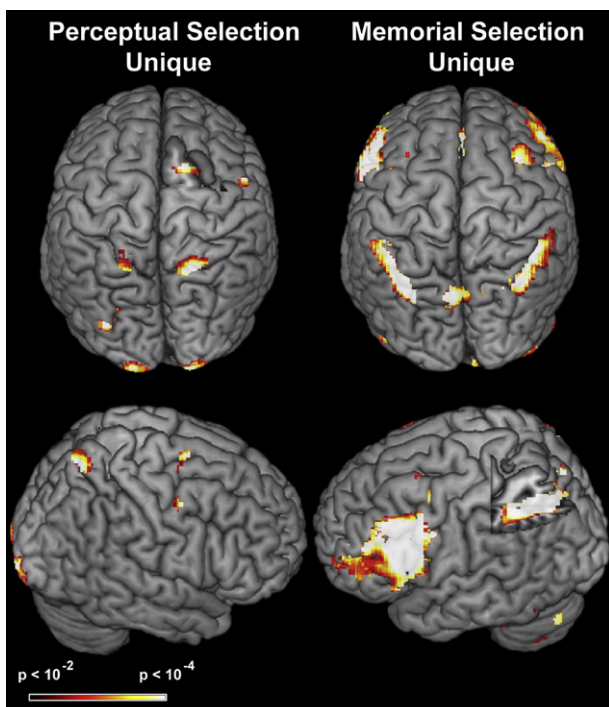

**Fig. 3.** Selection-specific results. Regions unique to perceptual selection are depicted on the left, and regions unique to memorial selection are depicted on the right.



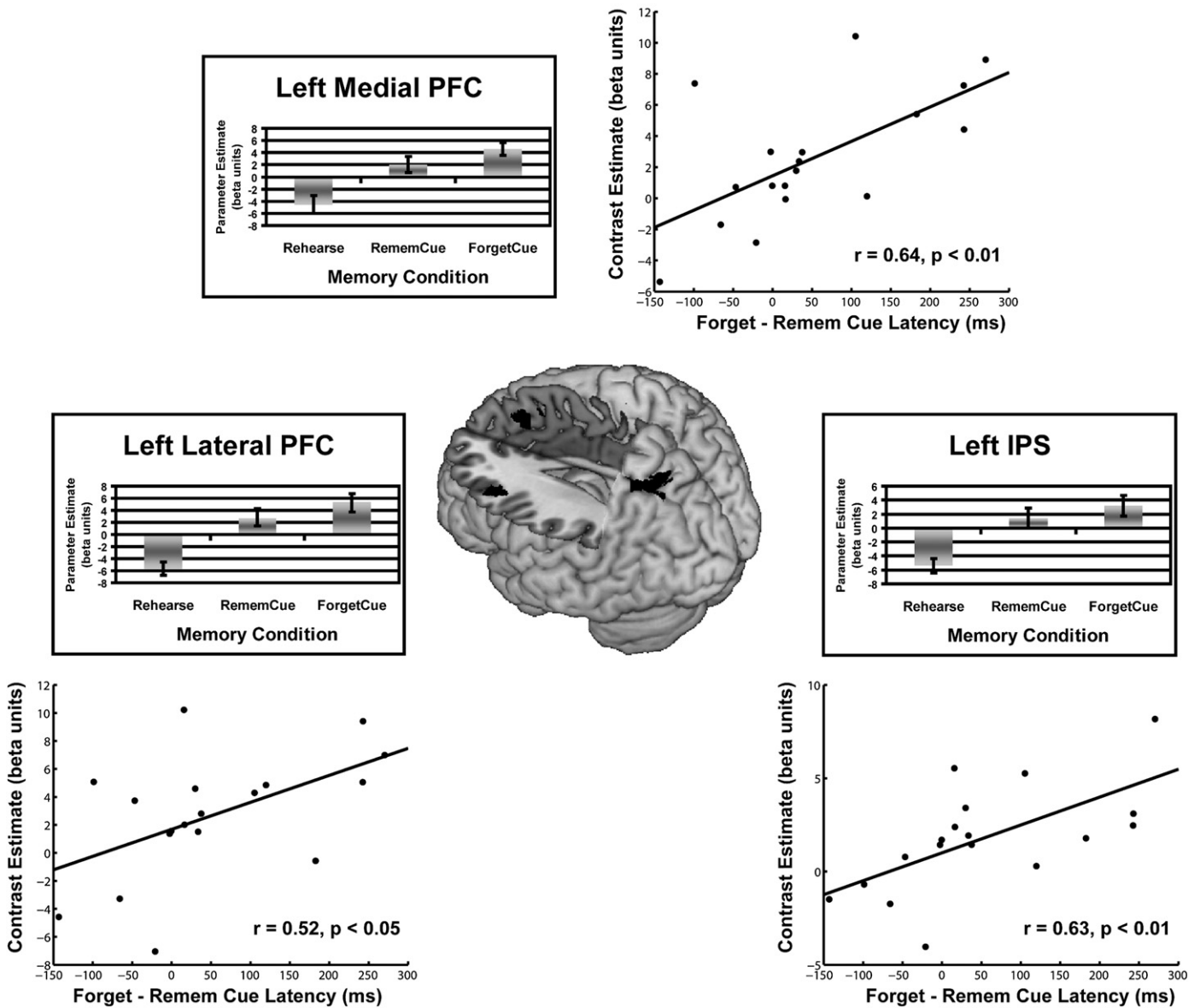

Fig. 4. Memorial selection-specific brain-behavior correlations. Regions that were involved in memorial selection, more strongly activated for forget cues compared to remember cues, and that correlated with behavioral measures of selection latency. PFC = prefrontal cortex; IPS = intraparietal sulcus.

interference. This would suggest that greater selection-related activation during memorial selection may lead to reduced proactive interference during probe decisions.

An alternative possibility is that both memory updating and resolving probe-related proactive interference are the same function, and the degree to which subjects have difficulty with one, they are

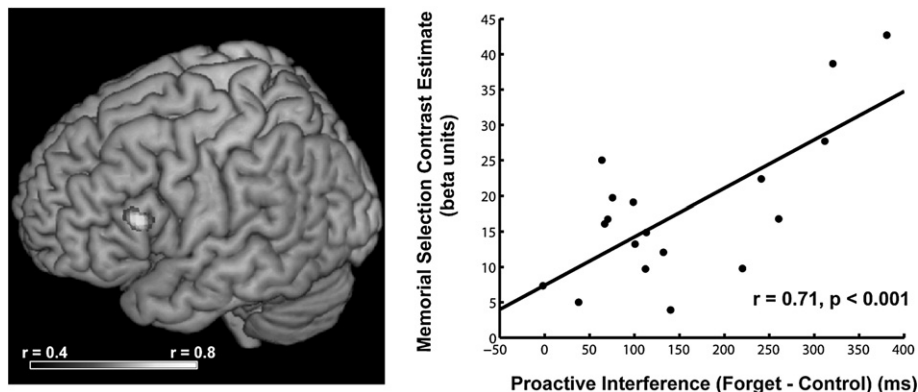
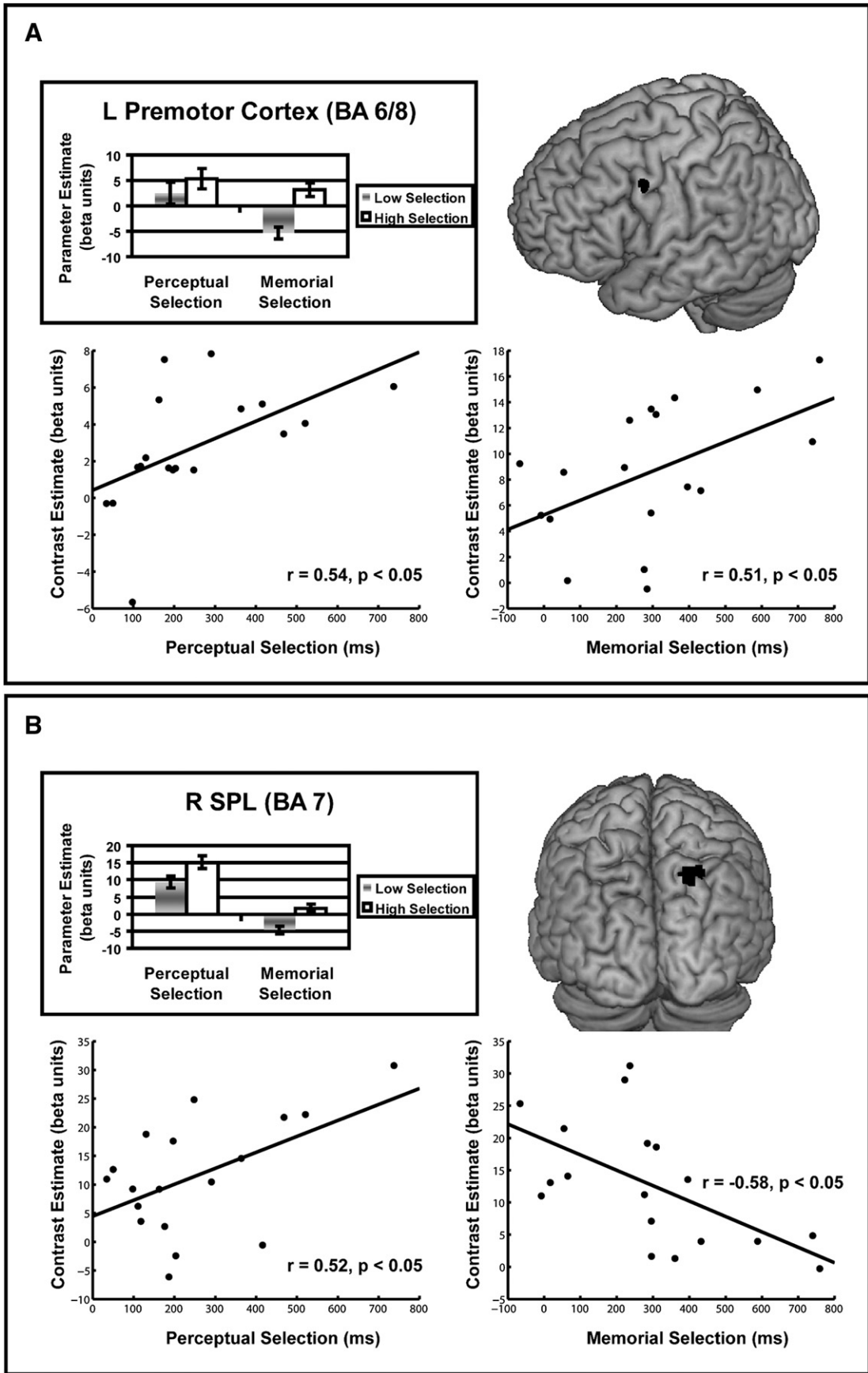

Fig. 5. Memorial selection-related activation in left ventrolateral prefrontal cortex predicted the amount of proactive interference experienced to forget probes compared to control probes. Voxel-wise correlations between activation and behavior are rendered on the left. Correlations pooled over all significant voxels are plotted on the right.





**Fig. 6.** Regions significant in the conjunction analysis that correlated with behavioral measures of selection difficulty for both perceptual and memorial selection. Selection-related activation in the left premotor cortex (A) correlated positively with behavioral measures of both perceptual and memorial selection. Selection-related activation in the right superior parietal lobe (B) correlated positively with behavioral measures of perceptual selection, but negatively with behavioral measures of memorial selection. SPL = superior parietal lobe.

likely to have difficulty with the other. That is, in both instances subjects are selecting among memorial representations, and difficulty in selection during memory updates should predict difficulty in selection when probed with a highly familiar irrelevant item. We have shown that left VLPFC activation increases during memorial selection correlate positively with behavioral measures of memorial selection, suggesting that greater difficulty with selection is associated with greater left VLPFC activation. If left VLPFC reflects general memorial selection demands, we would expect that greater selection-related activation may also predict higher proactive interference during probe decisions.

To test these alternative predictions, we examined whether activation in left VLPFC predicted the amount of proactive interference subjects experienced during recognition decisions. Proactive interference was indexed as the reaction time difference between decisions to forget probes compared to control probes, consistent with previous reports (Zhang et al., 2003; Jonides and Nee, 2006; Nee and Jonides, 2008). We looked in left VLPFC regions that showed significant activation increases to memorial selection demands and examined whether any of these regions were correlated with behavioral measures of proactive interference at the time of the probe.

Activation during memorial selection in left VLPFC correlated strongly with subsequent proactive interference (MNI center  $-52\ 22\ 18$ , BA 45, 178 voxels,  $r=0.71$ ,  $p<0.001$ ; Fig. 5). The correlation was positive indicating that subjects who demonstrated increased activation during memorial selection also experienced greater proactive interference to later probes. Hence, this region was correlated with increased behavioral measures of memorial selection demands during selection, as well as increased behavioral measures of proactive interference several seconds after selection. The combination of these results suggests that memory updating and resolving proactive interference recruit common mechanisms of memorial selection, and that subjects that show difficulty in one process also show difficulty in the other.

#### Common neural and behavioral interactions

We were interested in whether neural activation in any of the common regions uncovered by our conjunction analysis could reveal a demonstrable relation to behavior. To explore this issue, we looked for regions where neural indices of selection demands correlated with behavioral indices of selection demands for both perceptual and memorial selection. We restricted this search to voxels that were significant in our conjunction analysis.

In left premotor cortex, lateral and inferior to the FEF (MNI center  $-54\ 6\ 42$ , BA 6/8, 17 voxels; Fig. 6a), activation increases related to increased selection demands were positively correlated with behavioral measures of both memorial selection ( $r=0.51$ ,  $p<0.05$ ) and perceptual selection ( $r=0.54$ ,  $p<0.05$ ). It is unlikely that this region reflected a response to the keypress since selection-related keypresses were all made with the left thumb. However, responses to recognition probes were all made with the right hand. Recognition probes appeared several seconds after perceptual and memorial selection occurred. Hence, it is possible that commonalities in this region may reflect preparation for upcoming recognition decisions. Such preparation may involve the biasing of relevant stimulus–response associations under high demand, to prevent potential interference from irrelevant stimulus–response associations.

#### Individual differences in common control

A region in the right SPL also demonstrated brain–behavior correlations for both kinds of selection (MNI center  $24\ -72\ 56$ , BA 7, 74 voxels; Fig. 6b). Interestingly, correlations in this region were in opposite directions for perceptual and memorial selection. Whereas selection-related activation increases were positively correlated with behavioral measures of perceptual selection ( $r=0.52$ ,  $p<0.05$ ), the opposite held true for memorial selection ( $r=-0.58$ ,  $p<0.05$ ). That is,

greater activation increases in this region were related to reduced behavioral differences between high and low selection for the memorial selection task. By contrast, activation increases in this region during perceptual selection scaled with behavioral selection effects for the perceptual selection task.

As depicted in Fig. 6b, the right SPL region was much more engaged during the perceptual selection task than the memorial selection task ( $t(17)=7.5$ ,  $p<0.001$ ), suggesting a strong attentional role for this region. Moreover, our previous analysis identified other portions of the SPL to be unique to perceptual selection, suggesting that the SPL in general may be more strongly related to selective attention than working memory. Therefore, one way to interpret this result is that subjects vary in the degree to which they recruit perceptual selection resources to perform memorial selection. Some subjects show strong commonalities, using attention-related SPL resources to perform memorial selection. As the correlation in Fig. 6b indicates, such recruitment may be beneficial in that these subjects demonstrated reduced behavioral differences between high and low memorial selections. Other subjects, by contrast, may show greater distinctions between perceptual and memorial selection. Such subjects would likely show greater use of regions unique for memorial selection, such as left VLPFC, when performing memorial selection.

To examine this proposal, we performed a median split on the data, dividing subjects into 2 groups: a high SPL group that showed greater activation increases in the right SPL for memorial selection, and a low SPL group that showed lower activation increases in the right SPL for memorial selection. Next, we re-ran whole-brain contrasts for memorial selection for each group separately. The results are depicted in Fig. 7. Not surprisingly, the high SPL group demonstrated stronger activation increases in the right SPL. This group also showed greater selection-related increases in the bilateral FEF and right premotor cortex. These frontal regions overlapped with our conjunction analysis and were close to regions that were unique to perceptual selection. Hence, memorial selection in these subjects

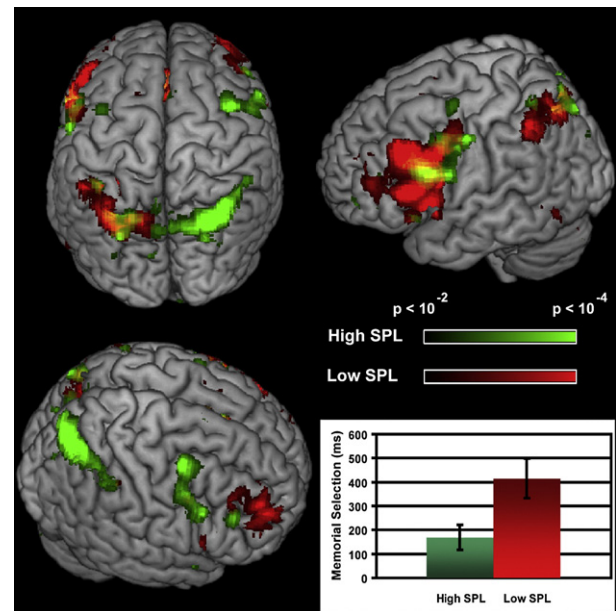

**Fig. 7.** Differences in memorial selection as a function of right superior parietal lobule recruitment. Subjects that showed large activation increases in the right superior parietal lobule (SPL) for memorial selection (high SPL; green) demonstrated enhanced activation in perceptual selection-related regions. Subjects that showed smaller activation increases in the right SPL (low SPL; red) demonstrated more robust activation in left ventrolateral prefrontal cortex, which was unique to memorial selection. Behavioral results indicated less selection difficulty for high SPL subjects compared to low SPL subjects.

appeared very similar to perceptual selection. By contrast, the low SPL group did not show significant activation increases in the right SPL, or FEF. Instead, this group showed much greater memorial selection-related activation increases in the left VLPFC, a region that we demonstrated to be unique to memorial selection. Finally, the groups demonstrated significant differences in behavioral measures of memorial selection with the high SPL group showing reduced differences between high and low selection compared to the low SPL group ( $t(16)=2.5$ ,  $p<0.05$ ).

This pattern of results suggests that subjects vary a great deal in the degree to which they recruit common neural resources of perceptual and memorial selection. Using common neural resources for perceptual and memorial selection was associated with better performance (i.e. reduced increases in latency for high selection demands), suggesting that it is beneficial to use selective attention resources to aid memorial selection.

## Discussion

We examined the common and unique neural components of selecting among competing percepts and memories. Consistent with models that posit that similar selection processes operate on all varieties of information, we found a broad network of overlapping activation between perceptual and memorial selection. Selection of both sorts was associated with activation increases in bilateral FEF, premotor cortex, DLPFC, medial PFC, anterior cingulate cortex, and the SPL. However, our results suggest that regions of the FEF and SPL are more strongly associated with perceptual selection, while memorial selection was uniquely associated with VLPFC, particularly on the left, and bilateral IPS. Moreover, left VLPFC activation correlated with behavioral measures of memorial selection demands, and activation in this region also predicted behavioral measures of proactive interference that appeared several seconds later. Finally, there was a considerable amount of individual variability in the degree to which subjects recruited the same neural resources for perceptual and memorial selection, and those subjects that more closely recruited overlapping resources demonstrated better performance.

### *Common dorsolateral prefrontal recruitment*

In contrast to previous reports (Labar et al., 1999; Pollmann and von Cramon, 2000; Nobre et al., 2004; Mayer et al., 2007), we found common selection-related activation increases in bilateral DLPFC. Models of selection posit that this region may store goal or template information used to guide selection in more posterior regions of cortex (Desimone and Duncan, 1995; Kastner and Ungerleider, 2000; Miller and Cohen, 2001). Goal or template information is especially important when selection cannot proceed in a purely bottom-up fashion. When competing distractors are present, information about current goals must be able to bias competition so that only goal-relevant information is processed. Consistent with these ideas, in both selective attention (Nee et al., 2007b) and working memory (D'Esposito and Postle, 1999; Smith and Jonides, 1999; Wager and Smith, 2003; Jonides et al., 2005), the DLPFC appears to be especially important when selection demands are increased by the presence of distracting information. In previous reports that have compared attention and memory, competition from distracting information has been minimized (Labar et al., 1999; Pollmann and von Cramon, 2000; Nobre et al., 2004; Mayer et al., 2007), which may account for previous failures to find common DLPFC recruitment across attention and memory. Here, we were careful to highlight selection processes of both attention and memory, rather than examining processes that simply maintain attention or hold information online. Hence, our results suggest that the DLPFC is critically involved in both attention and memory when selection processes must resolve competition from salient distraction.

### *Common attentional circuit*

As in previous reports (Labar et al., 1999; Pollmann and von Cramon, 2000; Nobre et al., 2004; Mayer et al., 2007), we found common involvement of the FEF, premotor cortex, and SPL across both perceptual and memorial selection. These regions have been robustly associated with attention (Kastner et al., 1999; Kastner and Ungerleider, 2000; Corbetta et al., 2002) and spatial working memory (Awh et al., 1999; Awh and Jonides, 2001; Awh et al., 2006). Awh et al. have suggested that in spatial working memory, this network acts as a focus of attention that cycles through spatial locations held in mind. In other words, spatial working memory is akin to cycled deployments of covert attention, explaining the great deal of overlap between attention and spatial working memory. However, our results demonstrate that this network need not be restricted to spatial information in that we assessed working memory for verbal material. That this network is also engaged in selecting among verbal representations suggests that attentional processes need not be spatial in manner, but can highlight information that lacks a visuo-spatial component.

Another possibility is that during memorial selection, subjects created a visuo-spatial representation of the information held in working memory, and used attentional processes to select among this information. For example, subjects may have imagined the original display and used attention to select among items in this visuo-spatial representation. An alternative account is that subjects stored the verbal information in an articulatory loop (Baddeley, 2003), which has a natural dimension of time (i.e. position within the rehearsal loop). Using such a representation, subjects may have translated the update cues to positional cues that targeted different serial positions within rehearsal. In any case, it is clear that attentional selection can be deployed to select among memorial representations.

Common recruitment of left premotor cortex closely tracked behavioral measures of both perceptual and memorial selection. Since responses to selection demands were made with the left hand, it is unlikely that these results reflect response processes. However, responses to recognition probes performed several seconds later were made with the right hand. Therefore, activation in this region may have reflected the biasing of stimulus–response pathways to guard against interference in preparation for future response production. Alternatively, this region may also have been involved in the deployment of attention. Although the human FEF is most often localized to the junction of the superior frontal sulcus and precentral sulcus, there are demonstrations of oculomotor-associated cortex more lateral and inferior near the premotor region we found here (Lobel et al., 2001). Hence, this region may also be associated with attentional biasing to resolve competition.

### *Left ventrolateral prefrontal cortex and memorial selection*

Our results indicated that left VLPFC was unique to memorial selection and that activation in this region was closely tied to behavioral manifestations of selection difficulty and proactive interference. Lesions in this region, particularly in BA 45, cause selective deficits in the ability to resolve proactive interference (Thompson-Schill et al., 2002; Hamilton and Martin, 2005), but spare other forms of working memory performance. Based on these results, some authors have hypothesized that this region is involved in selecting among contextual information in order to appropriately categorize the source of highly familiar information (Badre and Wagner, 2005; Jonides and Nee, 2006; Nee et al., 2007a). This region is also involved in selecting among competing semantic representations (Thompson-Schill et al., 1997; Nelson, 2005; Badre and Wagner, 2007) and hence, this region may serve a general memorial selection function (Zhang et al., 2004). Our results are consistent with these ideas in that activation in this region was associated with memorial selection difficulty, and



activation also predicted future difficulty in how well subjects resolved proactive interference.

Braver et al. (2007) have suggested that selection processes of left VLPFC may be engaged in a proactive manner in order to mitigate future effects of proactive interference. Engagement of this region during updating had the potential to investigate whether greater use of selection processes of left VLPFC during updating would lead to reduced proactive interference at the time of the probe. We did not find this pattern. Instead, difficulty during memory updating was associated with difficulty during recognition decisions, suggesting that the same process was elicited in both scenarios. However, our results do not preclude other potential proactive strategies such as increased selection during the retention interval after updating and before the recognition probe. Although our design did not permit a separate assessment of delay period activation, an interesting future pursuit would be to examine the interplay between cue-related, delay-related, and probe-related activation in left VLPFC to investigate potential processes of proactive and reactive control.

Preferential involvement of left VLPFC in memorial selection may also have been due to the verbal nature of memorial selection. Although perceptual selection was also performed on verbal materials, such selection was done in a visuo-spatial manner that may have attenuated verbal aspects of processing. However, previous studies contrasting attention and working memory using objects that are difficult to name (Mayer et al., 2007), as well as spatial locations (Nobre et al., 2004) also found greater memory-related activation in left VLPFC compared to attention. Left VLPFC involvement in the resolution of proactive interference has also been found for non-verbal material (Postle et al., 2004; Jonides and Nee, 2006), although these effects have not always been found (Leung and Zhang, 2004; Badre and Wagner, 2005). Hence, although we cannot rule out a verbal involvement for left VLPFC, it remains possible that this region responds generally to memorial selection.

#### *Control operations of the intraparietal sulcus*

Previous comparisons of attention and memory have demonstrated largely overlapping activation in the IPS (Labar et al., 1999; Pollmann and von Cramon, 2000; Nobre et al., 2004; Mayer et al., 2007). Our results demonstrated very little overlap in this region, with the IPS being almost exclusively associated with memorial selection. One difference between our attention task and others is that for all of our conditions, attention shifting was closely matched, whereas in other studies, contrasts of interest included processes involved in shifting attention. The IPS is known to be involved in attentional shifts (Wager et al., 2004) and the lack of involvement during perceptual selection here may be because our contrasts subtracted out this process. By contrast, there may have been shifting operations during memorial selection as subjects shifted from maintenance operations to updating, or shifting their attention among different information in memory.

Alternative accounts suggest that rather than being associated with shifting, the IPS is involved in maintaining attention on target information (Yantis and Serences, 2003; Serences et al., 2004). Tonic activation in the IPS is associated with maintaining attention both to perceptual (Serences et al., 2004) and memorial information (Todd and Marois, 2004; 2005; Vogel and Machizawa, 2004; Vogel, 2005; Xu and Chun, 2006). Once again, our perceptual selection contrast may have subtracted this process out, but alterations in maintenance operations likely occurred for memory updating operations. During memory updates, maintenance is interrupted and attention is shifted and maintained on updated information. Hence, the reason that we found IPS involvement in memory, but not attention may be due to the particular contrasts performed here. It is clear from other work that the IPS is involved in both attention and memory (Labar et al., 1999; Pollmann and von Cramon, 2000; Nobre

et al., 2004; Mayer et al., 2007), and our design may simply not have afforded detecting these commonalities.

#### *Individual variations in common control*

Our analyses suggested that regions of the FEF, premotor cortex, and SPL may have been preferentially engaged in perceptual selection, and that subjects varied in the degree to which they used these same networks for memorial selection. Such variation may be accounted for by differences in representational strategy. As alluded to above, subjects may have differed in the degree to which they relied on visuo-spatial or timing strategies in working memory. Memorial representations that highlighted visuo-spatial or timing aspects of the information in working memory may have been more amenable to perceptual selection types of processes. Subjects who recruited more perceptual selection regions of the SPL and FEF for memorial selection also demonstrated less difficulty for high memorial selection demands, compared to subjects who relied more on left VLPFC. These results suggest that perceptual selection strategies may be beneficial to memory performance. An interesting avenue for future research would be to examine whether explicitly giving subjects such perceptual selection strategies for memorial selection can improve performance.

Notably, in our tasks, perceptual and memorial selection were performed independently. Previous studies that have examined selective attention and memory in dual task situations have found that these processes interfere with one another when performed concurrently (de Fockert et al., 2001; Lavie et al., 2004; Lavie, 2005). This research may predict that those subjects who demonstrated *less* sharing of perceptual and memorial selection may actually demonstrate *better* performance under dual task situations, since those subjects can draw from separate neural resources to perform each function. This is another interesting avenue for future investigation.

#### *Conclusion*

Top-down control allows the cognitive system to represent only information that is relevant to current goals. We have demonstrated that similar forms of top-down control underlie selecting among competing percepts and memories. These processes may be subserved by interactions between goal and template information held in the DLPFC that biases the deployment of FEF and SPL attentional processes in the face of competing distraction. When selecting among competing memories, regions of the left VLPFC are additionally recruited. Although not all control processes are shared, there appear to be benefits to a cognitive economy of re-using the same processes for perceptual and memorial selection, at least when both selections can be performed independently.

#### **Acknowledgments**

This research was supported in part by the National Science Foundation under Grant No. 0520992, in part by grant MH60655 from NIMH, and in part by a National Science Foundation Graduate Research Fellowship awarded to the first author.

#### **Appendix A. Supplementary data**

Supplementary data associated with this article can be found, in the online version, at [doi:10.1016/j.neuroimage.2009.01.005](https://doi.org/10.1016/j.neuroimage.2009.01.005).

#### **References**

- Awh, E., Jonides, J., 2001. Overlapping mechanisms of attention and spatial working memory. *Trends Cogn. Sci.* 5, 119–126.
- Awh, E., Jonides, J., Smith, E.E., Buxton, R.B., Frank, L.R., Love, T., Wong, E.C., Gmeindl, L., 1999. Rehearsal in spatial working memory: evidence from neuroimaging. *Psychol. Sci.* 10, 433–437.



- Awh, E., Vogel, E.K., Oh, S.H., 2006. Interactions between attention and working memory. *Neuroscience* 139, 201–208.
- Baddeley, A.D., 2003. Working memory: looking back and looking forward. *Nat. Rev. Neurosci.* 4, 829–839.
- Badre, D., Wagner, A.D., 2005. Frontal lobe mechanisms that resolve proactive interference. *Cereb. Cortex* 15, 2003–2012.
- Badre, D., Wagner, A.D., 2007. Left ventrolateral prefrontal cortex and the cognitive control of memory. *Neuropsychologia* 45, 2883–2901.
- Bisiach, E., Luzzatti, C., 1978. Unilateral neglect of representational space. *Cortex* 14, 129–133.
- Bisiach, E., Luzzatti, C., Perani, D., 1979. Unilateral neglect, representational schema and consciousness. *Brain* 102, 609–618.
- Braver, T.D., Gray, J.R., Burgess, G.C., 2007. Explaining the many varieties of working memory variation: dual mechanisms of cognitive control. In: Conway, A., Jarrold, C., Kane, M., Miyake, A., Towse, J. (Eds.), *Variation in Working Memory*. Oxford University Press, New York, pp. 76–106.
- Chelazzi, L., Miller, E.K., Duncan, J., Desimone, R., 1993. A neural basis for visual search in inferior temporal cortex. *Nature* 363, 345–347.
- Chelazzi, L., Duncan, J., Miller, E.K., Desimone, R., 1998. Responses of neurons in inferior temporal cortex during memory-guided visual search. *J. Neurophysiol.* 80, 2918–2940.
- Corbetta, M., Shulman, G.L., 2002. Control of goal-directed and stimulus-driven attention in the brain. *Nat. Rev. Neurosci.* 3, 201–215.
- Corbetta, M., Kincade, J.M., Shulman, G.L., 2002. Neural systems for visual orienting and their relationships to spatial working memory. *J. Cogn. Neurosci.* 14, 508–523.
- Damasio, A.R., Damasio, H., Chang, C.H., 1980. Neglect following damage to frontal lobe or basal ganglia. *Neuropsychologia* 18, 123–132.
- D'Esposito, M., Postle, B.R., 1999. The dependence of span and delayed-response performance on prefrontal cortex. *Neuropsychologia* 37, 1303–1315.
- D'Esposito, M., Postle, B.R., Jonides, J., Smith, E.E., Lease, J., 1999. The neural substrate and temporal dynamics of interference effects in working memory as revealed by event-related fMRI. *Proc. Natl. Acad. Sci. U. S. A.* 96, 7514–7519.
- de Fockert, J.W., Rees, G., Frith, C.D., Lavie, N., 2001. The role of working memory in visual selective attention. *Science* 291, 1803–1806.
- Deco, G., Rolls, E.T., 2005. Attention, short-term memory, and action selection: a unifying theory. *Prog. Neurobiol.* 76, 236–256.
- Desimone, R., Duncan, J., 1995. Neural mechanisms of selective visual attention. *Annu. Rev. Neurosci.* 18, 193–222.
- Engle, R.W., Kane, M.J., Tuholski, S.W., 1999. Individual differences in working memory capacity and what they tell us about controlled attention, general fluid intelligence and functions of the prefrontal cortex. In: Miyake, A., Shah, P. (Eds.), *Models of Working Memory*. Cambridge University Press, Cambridge, UK, pp. 102–134.
- Fitts, P.M., Seeger, C.M., 1953. S–R compatibility: spatial characteristics of stimulus and response codes. *J. Exp. Psychol.* 46, 199–211.
- Forman, S.D., Cohen, J.D., Fitzgerald, M., Eddy, W.F., Mintun, M.A., Noll, D.C., 1995. Improved assessment of significant activation in functional magnetic resonance imaging (fMRI): use of a cluster-size threshold. *Magn. Reson. Med.* 33, 636–647.
- Fox, E., 1995. Negative priming from ignored distractors in visual selection: a review. *Psychon. Bull. Rev.* 2, 145–173.
- Fuster, J.M., Bauer, R.H., Jervey, J.P., 1985. Functional interactions between inferotemporal and prefrontal cortex in a cognitive task. *Brain Res.* 330, 299–307.
- Gazzaley, A., D'Esposito, M., 2007. Top-down modulation and normal aging. *Ann. N.Y. Acad. Sci.* 1097, 67–83.
- Hamilton, A.C., Martin, R.C., 2005. Dissociations among tasks involving inhibition: a single-case study. *Cogn. Affect. Behav. Neurosci.* 5, 1–13.
- Heilman, K.M., Valenstein, E., 1972. Frontal lobe neglect in man. *Neurology* 22, 660–664.
- Jenkinson, M., Bannister, P., Brady, M., Smith, S., 2002. Improved optimization for the robust and accurate linear registration and motion correction of brain images. *NeuroImage* 17, 825–841.
- Jonides, J., Nee, D.E., 2006. Brain mechanisms of proactive interference in working memory. *Neuroscience* 139, 181–193.
- Jonides, J., Smith, E.E., Marshuetz, C., Koeppe, R.A., Reuter-Lorenz, P.A., 1998. Inhibition in verbal working memory revealed by brain activation. *Proc. Natl. Acad. Sci. U. S. A.* 95, 8410–8413.
- Jonides, J., Lacey, S.C., Nee, D.E., 2005. Processes of working memory in mind and brain. *Curr. Dir. Psychol. Sci.* 14, 2–5.
- Kane, M.J., Bleckley, M.K., Conway, A.R.A., Engle, R.W., 2001. A controlled-attention view of working memory capacity: individual differences in memory span and the control of visual orienting. *J. Exp. Psychol. Gen.* 126, 169–183.
- Kastner, S., Ungerleider, L.G., 2000. Mechanisms of visual attention in the human cortex. *Annu. Rev. Neurosci.* 23, 315–341.
- Kastner, S., Pinsk, M.A., De Weerd, P., Desimone, R., Ungerleider, L.G., 1999. Increased activity in human visual cortex during directed attention in the absence of visual stimulation. *Neuron* 22, 751–761.
- Labar, K.S., Gitelman, D.R., Parrish, T.B., Mesulam, M., 1999. Neuroanatomic overlap of working memory and spatial attention networks: a functional MRI comparison within subjects. *NeuroImage* 10, 695–704.
- Lavie, N., 2005. Distracted and confused?: selective attention under load. *Trends Cogn. Sci.* 9, 75–82.
- Lavie, N., Hirst, A., de Fockert, J.W., Viding, E., 2004. Load theory of selective attention and cognitive control. *J. Exp. Psychol. Gen.* 133, 339–354.
- Lazar, N.A., Eddy, W.F., Genovese, C.R., Welling, J., 2001. Statistical issues in fMRI for brain imaging. *Int. Stat. Rev.* 69, 105–127.
- Lepsien, J., Nobre, A.C., 2006. Cognitive control of attention in the human brain: insights from orienting attention to mental representations. *Brain Res.* 1105, 20–31.
- Leung, H.C., Zhang, J.X., 2004. Interference resolution in spatial working memory. *NeuroImage* 23, 1013–1019.
- Lobel, E., Kahane, P., Leonards, U., Grosbras, M.H., Lehericy, S., Le Bihan, D., Berthoz, A., 2001. Localization of human frontal eye fields: anatomical and functional findings of functional magnetic resonance imaging and intracerebral electrical stimulation. *J. Neurosurg.* 95, 804–815.
- Lund, T.E., Norgaard, M.D., Rostrup, E., Rowe, J.B., Paulson, O.B., 2005. Motion or activity: their role in intra- and inter-subject variation in fMRI. *Neuroimage* 26, 960–964.
- May, C.P., Kane, M.J., Hasher, L., 1995. Determinants of negative priming. *Psychol. Bull.* 118, 35–54.
- Mayer, J.S., Bittner, R.A., Nikolic, D., Bledowski, C., Goebel, R., Linden, D.E., 2007. Common neural substrates for visual working memory and attention. *NeuroImage* 36, 441–453.
- Miller, E.K., Cohen, J.D., 2001. An integrative theory of prefrontal cortex function. *Annu. Rev. Neurosci.* 24, 157–202.
- Mishkin, M., 1957. Effects of small frontal lesions on delayed alternation in monkeys. *J. Neurophysiol.* 20, 615–622.
- Nee, D.E., Jonides, J., 2008. Dissociable interference-control processes in perception and memory. *Psychol. Sci.*
- Nee, D.E., Jonides, J., Berman, M.G., 2007a. Neural mechanisms of proactive interference-resolution. *NeuroImage* 38, 740–751.
- Nee, D.E., Wager, T.D., Jonides, J., 2007b. Interference resolution: insights from a meta-analysis of neuroimaging tasks. *Cogn. Affect. Behav. Neurosci.* 7, 1–17.
- Nelson, J.K., 2005. *Interference Resolution in the Left Inferior Frontal Gyrus*. PhD Dissertation. University of Michigan.
- Nelson, J.K., Reuter-Lorenz, P.A., Sylvester, C.Y.C., Jonides, J., Smith, E.E., 2003. Dissociable neural mechanisms underlying response based and familiarity-based conflict in working memory. *Proc. Natl. Acad. Sci. U. S. A.* 100, 11171–11175.
- Nobre, A.C., Coull, J.T., Maquet, P., Frith, C.D., Vandenberghe, R., Mesulam, M.M., 2004. Orienting attention to locations in perceptual versus mental representations. *J. Cogn. Neurosci.* 16, 363–373.
- Oppenheim, A.V., Schaffer, R.W., Buck, J.R., 1999. *Discrete-Time Signal Processing*, 2nd Ed. Prentice Hall, Upper Saddle River, NJ.
- Poline, J.B., Worsley, K.J., Evans, A.C., Friston, K.J., 1997. Combining spatial extent and peak intensity to test for activations in functional imaging. *NeuroImage* 5, 83–96.
- Pollmann, S., von Cramon, D.Y., 2000. Object working memory and visuospatial processing: functional neuroanatomy analyzed by event-related fMRI. *Exp. Brain Res.* 133, 12–22.
- Postle, B.R., Brush, L.N., 2004. The neural bases of the effects of item nonspecific proactive interference on working memory. *Cogn. Affect. Behav. Neurosci.* 4, 379–392.
- Postle, B.R., Brush, L.N., Nick, A.M., 2004. Prefrontal cortex and the mediation of proactive interference in working memory. *Cogn. Affect. Behav. Neurosci.* 4, 600–608.
- Ranganath, C., 2006. Working memory for visual objects: complementary roles of inferior temporal, medial temporal, and prefrontal cortex. *Neuroscience* 139, 277–289.
- Rowe, J.B., Stephan, K.E., Friston, K., Frackowiak, R.S.J., Passingham, R.E., 2005. The prefrontal cortex shows context-specific changes in effective connectivity to motor or visual cortex during the selection of action or colour. *Cereb. Cortex* 15, 85–95.
- Serences, J.T., Schwarzbach, J., Courtney, S.M., Golay, X., Yantis, S., 2004. Control of object-based attention in human cortex. *Cereb. Cortex* 14, 1346–1357.
- Smith, E.E., Jonides, J., 1999. Storage and executive processes in the frontal lobes. *Science* 283, 1657–1661.
- Smith, S.M., Jenkinson, M., Woolrich, M.W., Beckmann, C.F., Behrens, T.E.J., Johansen-Berg, H., Bannister, P.R., De Luca, M., Drobnjak, I., Flitney, D.E., Niazky, R.K., Saunders, J., Vickers, J., Zhang, Y., De Stefano, N., Brady, J.M., Matthews, P.M., 2004. Advances in functional and structural MR image analysis and implementation as FSL. *NeuroImage* 23, S208–S219.
- Thompson-Schill, S.L., D'Esposito, M., Aguirre, G.K., Farah, M.J., 1997. Role of left inferior prefrontal cortex in retrieval of semantic knowledge: a reevaluation. *Proc. Natl. Acad. Sci. U. S. A.* 94, 14792–14797.
- Thompson-Schill, S.L., Jonides, J., Marshuetz, C., Smith, E.E., D'Esposito, M., Kan, I.P., Knight, R.T., Swick, D., 2002. Effects of frontal lobe damage on interference effects in working memory. *Cogn. Affect. Behav. Neurosci.* 2, 109–120.
- Tipper, S.P., 2001. Does negative priming reflect inhibitory mechanisms? A review and integration of conflicting views. *Q. J. Exp. Psychol.* 54A, 321–343.
- Todd, J.J., Marois, R., 2004. Capacity limit of visual short-term memory in human posterior parietal cortex. *Nature* 428, 751–754.
- Todd, J.J., Marois, R., 2005. Posterior parietal cortex activity predicts individual differences in visual short-term memory capacity. *Cogn. Affect. Behav. Neurosci.* 5, 144–155.
- Vogel, E.K., Machizawa, M.G., 2004. Neural activity predicts individual differences in visual working memory capacity. *Nature* 426, 748–751.
- Vogel, E.K., McCollough, A.W., Machizawa, M.G., 2005. Neural measures reveal individual differences in controlling access to working memory. *Nature* 438, 500–503.
- Wager, T.D., Smith, E.E., 2003. Neuroimaging studies of working memory: a meta-analysis. *Cogn. Affect. Behav. Neurosci.* 3, 255–274.
- Wager, T.D., Jonides, J., Reading, S., 2004. Neuroimaging studies of shifting attention: a meta-analysis. *NeuroImage* 22, 1679–1693.
- Wagner, A.D., Shannon, B.J., Kahn, I., Buckner, R.L., 2005. Parietal lobe contributions to episodic memory retrieval. *Trends Cogn. Sci.* 9, 445–453.
- Xu, Y., Chun, M.M., 2006. Dissociable neural mechanisms supporting visual short-term memory for objects. *Nature* 440, 91–95.
- Yantis, S., Serences, J.T., 2003. Cortical mechanisms of space-based and object-based attentional control. *Curr. Opin. Neurobiol.* 13, 187–193.
- Zhang, J.X., Leung, H.C., Johnson, M.K., 2003. Frontal activations associated with accessing and evaluating information in working memory: an fMRI study. *NeuroImage* 20, 1531–1539.
- Zhang, J.X., Feng, C.M., Fox, P.T., Gao, J.H., Tan, L.H., 2004. Is left inferior frontal gyrus a general mechanism for selection? *NeuroImage* 23, 596–603.
- Zhang, Y.Z., Du, Y.C., Zhang, J.X., 2008. Working memory selection and competition between target and distractor representations. *Psychol. Rep.* 102, 194–212.