

Design example – DAC

Recall from the last lecture, we can use an op amp as a comparator. However, as we've seen earlier, since the internal gain A is very large, in practice any input v_+ and v_- with a slight difference between them will result in an output $V_{out} = A(V_+ - V_-)$ that is clipped to either V_{DD} or V_{SS} . However, what if sometimes we would like to scale an input, but not to the point where that causes the op amp to clip out? As we will see later, **negative feedback** gives us a way to build blocks that depend only on ratio of physical quantities as long as the op amp has high enough (but not precise) internal gain. But let's first see an example of why this might be useful.

Our goal for this design is to use a digital analog converter (DAC) to build a home audio system.



The DAC takes in digital bits and converts them into an analog signal. Then this signal is fed into a speaker, as illustrated on the right. The maximum voltage the DAC can produce is 3.3V, and the minimum voltage the DAC can produce is 0V. However, you want the input voltage to the speaker to be between 0V and 10V (in order to make the speaker loud enough). So somehow you want to be able to map voltages from 0 to 3.3V to voltages from 0 to 10V. Suppose that we can model the speaker as an 8Ω resistor connected to ground and we model the DAC with its Thevenin equivalent with voltage V_{TH} and thevenin resistance $R_{TH} = 1k\Omega$. What if we connect the DAC and the speaker directly? We will have the following circuit

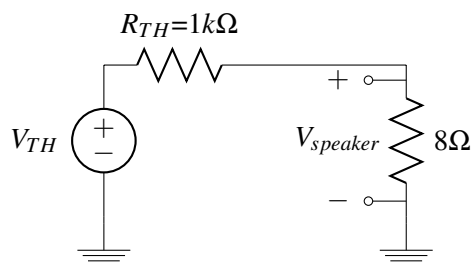

Now we can see that

$$V_{speaker} = \frac{8}{8 + 1000} \times V_{TH} \quad (1)$$

which is much smaller than V_{TH} . This definitely won't do what we would like.

What we really want in between the DAC and the speaker is something that provides a gain of roughly 3 ($10/3.3$) and acts as a buffer, i.e., that can measure the output voltage of the DAC, V_{DAC} , without affecting it, and for the output, we want to be able to draw any current the meet the spec. So we want something like the following

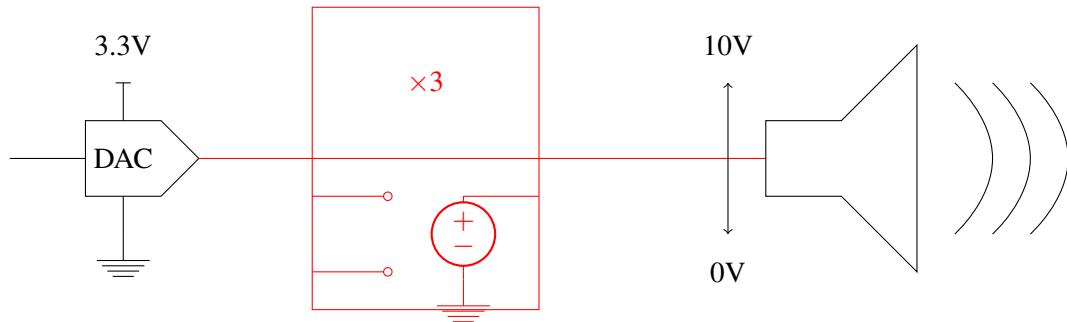

This looks just like the internal of an op amp! Now notice that based on what we know so far about op amps as comparators, we can't just scale the voltage linearly as we we would have wished: if we connect an ideal op amp (infinite internal gain) with $V_{DD} = 10V$ and $V_{SS} = 0V$, the output voltage would either be $10V$ or $0V$, but not something in between. To achieve what we would like, we need another tool, which we will introduce in the next section.

Negative feedback

Many real world control systems use negative feedback. Let's take a look at a generic block diagram for negative feedback systems.

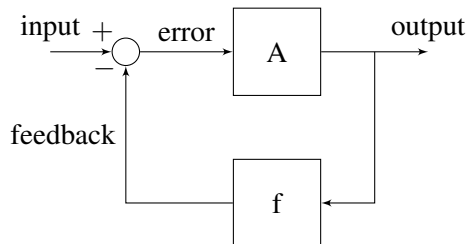

The idea is we take the difference between the input and a scaled version (multiplied by f) of the output, which we call feedback, and apply gain A on it to again produce the output.

Observe that if the feedback signal for some system (e.g. noise) is increased), the error (input - feedback) signal will decrease (move down), which then causes the output to go down as well, i.e., the loop has ability to suppress the original change in the feedback signal!

Now we can kind of get an intuitive idea of how negative feedback can be useful. When we want to get a system to have a desired output, negative feedback loops can help re-adjust to the value of the desired output when the output is too high or too low relative to the target value.

Now let's see how negative feedback loops can be realized in op amps. Consider the following circuit:

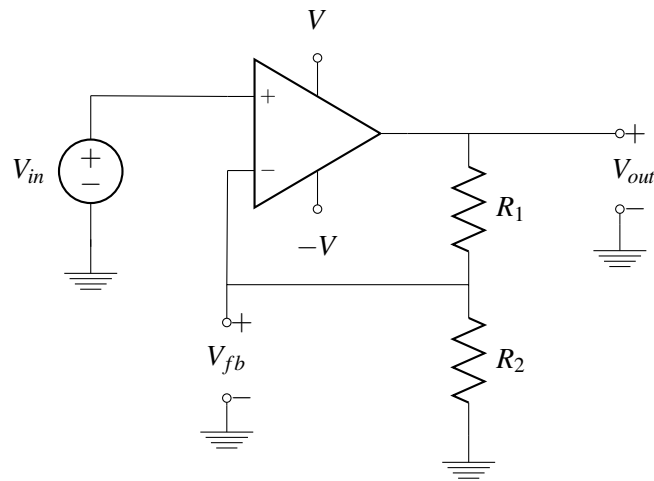

To help analyze circuits of this kind, we will introduce two "golden rules" that we could use to make our lives simpler.

Golden Rules

Recalling the op amp symbol from previous lecture

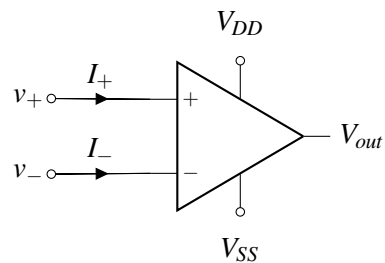

For an ideal op amp, the "golden rules" are

- (1) $I_+ = I_- = 0$. Now let's think about why this is the case. Recall that the equivalent op amp circuit is

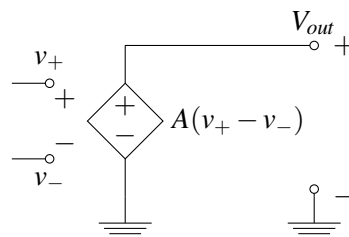

Notice that there is no closed circuit connected to the positive or negative input terminal of the op amp. Thus, no current can flow into the positive or negative input terminal. **Note that this rule holds regardless of whether there is negative feedback or not.**

- (2) $V_+ = V_-$: We will explain later why this is true, but intuitively this means that the "error signal" going into the op amp must be zero. One important thing to note now is this rule only holds when there is negative feedback.

Now let's use the golden rules to analyze the circuit we saw earlier:

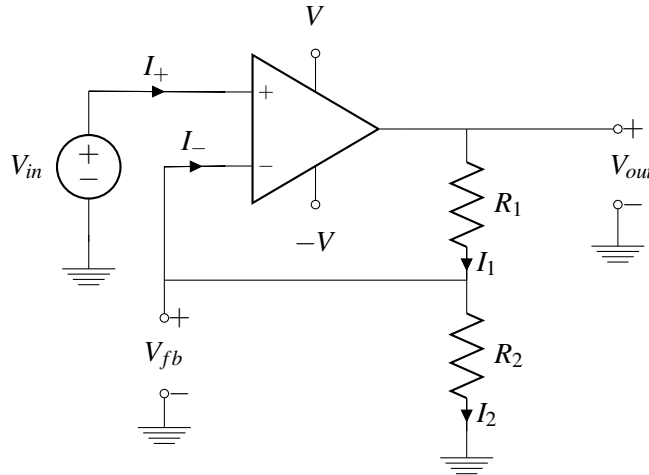

We know that by applying KCL at the junction between R_1 and R_2 , we have

$$I_1 = I_2 + I_- \quad (2)$$

By the first golden rule, we know that $I_+ = I_- = 0$. Hence,

$$I_1 = I_2 \quad (3)$$

Now let's apply the second golden rule, $V_+ = V_-$. Using this, we have

$$V_{in} = V_{fb} \quad (4)$$

Now we can solve for I_2 using Ohm's law, $V_{fb} = I_2 R_2$, hence

$$I_2 = \frac{V_{fb}}{R_2} \quad (5)$$

Using Ohm's law on R_1 , we also have $V_{out} - V_{fb} = I_1 R_1$. Hence,

$$I_1 = \frac{V_{out} - V_{fb}}{R_1} \quad (6)$$

However, we know that $I_1 = I_2$, which gives us the following relationship

$$I_1 = \frac{V_{out} - V_{fb}}{R_1} = \frac{V_{fb}}{R_2} = I_2 \quad (7)$$

which is equivalent to

$$I_1 = \frac{V_{out} - V_{in}}{R_1} = \frac{V_{in}}{R_2} = I_2. \quad (8)$$

Moving terms around, this gives us

$$V_{out} = V_{in} \left(1 + \frac{R_1}{R_2} \right). \quad (9)$$

Notice that here the ratio $\frac{V_{out}}{V_{in}}$ only depends on the ratio $\frac{R_1}{R_2}$. This is a great property since it is rather difficult to produce resistors with a particular absolute resistance. As long as the two resistors are produced with the same error rate ϵ , i.e., they have resistance $(1 + \epsilon)R_1$ and $(1 + \epsilon)R_2$, the ratio between their resistance will remain the same

$$\frac{(1 + \epsilon)R_1}{(1 + \epsilon)R_2} = \frac{R_1}{R_2}. \quad (10)$$

Second golden rule revisited

Recall that in the last section, we stated the second golden rule $V_+ = V_-$, i.e., the voltage at the positive input terminal (relative to ground) and the voltage at the negative input terminal (relative to the same ground) are the same when there is negative feedback. Now we would like to justify why this is the case. We return to the block diagram we drew earlier for a general negative feedback loop, but now focus on its application in circuits.

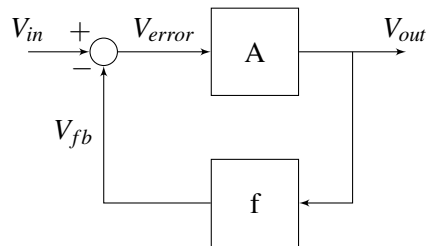

Observe that if V_{fb} remains unchanged and V_{in} goes up, then V_{error} goes up. Then since A is a positive number, V_{out} also goes up, which causes V_{fb} to go up. In other words, the magnitude of V_{error} goes down, meaning that the system is going to stabilize itself. Now what if we change the minus sign to a plus sign in the diagram, i.e., changing the system into a positive feedback system. With a similar logic, you could verify that if V_{in} goes up, V_{fb} goes up, but V_{error} goes up, which further causes V_{out} to go up. We see that it is not possible to stabilize the system. Let's look at the negative feedback op amp circuit we've seen earlier,

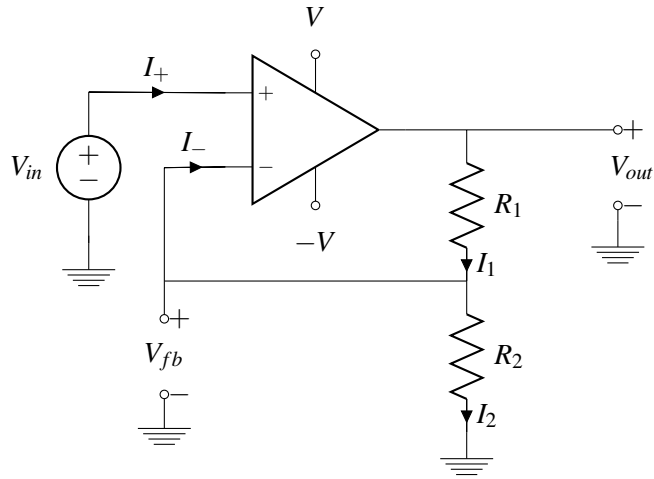

We know that when V_{in} increases, V_{out} also increases since $V_{out} = A(V_{in} - V_{fb})$. When V_{out} increases, $V_{fb} = \frac{R_2}{R_1 + R_2} V_{out}$ also increases, which then cause V_{error} , and hence, V_{out} to go down. (Note in this case, $f = \frac{R_2}{R_1 + R_2}$ in the block diagram.) Now let's derive why $V_+ = V_-$ in this case. We know that in the above circuit, $V_+ = V_{in}$ and $V_- = V_{fb}$. Let's redraw the block diagram.

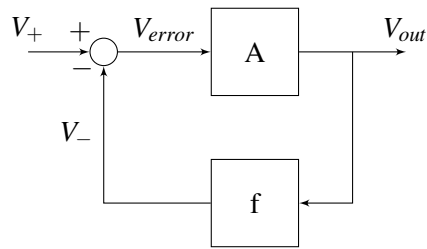

Now when the system stabilizes, we have

$$V_{error} = V_+ - V_- \quad (11)$$

$$V_{out} = AV_{error} = A(V_+ - V_-) \quad (12)$$

$$V_- = fV_{out} \quad (13)$$

Combining the last two equations, we have

$$V_{out} = A(V_+ - fV_{out}), \quad (14)$$

which gives us

$$V_{out}(1 + Af) = AV_+. \quad (15)$$

Finally, we have

$$V_{out} = \frac{A}{1 + Af} V_+. \quad (16)$$

Hence,

$$V_- = fV_{out} = \frac{fA}{1 + Af} V_+. \quad (17)$$

Now we know that the gain A is very large, hence fA is very large. Hence, the ratio

$$\frac{fA}{1 + Af} \approx 1. \quad (18)$$

Thus, when $A \rightarrow \infty$ which is what we assume for an ideal op amp, $V_+ = V_-$.

Inverting op amp

Let's apply what we've learned so far about Golden rules and negative feedback to the following op amp circuit:

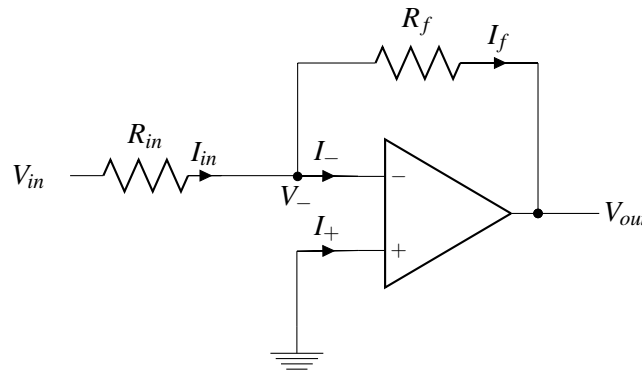

Given an ideal op-amp (with power rails of sufficiently large magnitude), what is V_{out} if we input an arbitrary voltage of V_{in} ?

The first golden rule says that $I_- = I_+ = 0$. Hence using KCL at the node labelled with voltage V_- , we have

$$I_{in} = I_- + I_f = 0 + I_f = I_f. \quad (19)$$

We have

$$I_{in} = I_f. \quad (20)$$

Now, let's apply the second golden rule, $V_+ = V_-$. Since the positive input terminal is connected to ground, $V_- = 0$. Hence, we have

$$V_+ = V_- = 0. \quad (21)$$

By Ohm's law,

$$I_{in} = \frac{V_{in} - V_-}{R_{in}} = \frac{V_{in}}{R_{in}} \quad (22)$$

$$I_f = \frac{V_- - V_{out}}{R_f} = -\frac{V_{out}}{R_f}. \quad (23)$$

Since $I_{in} = I_f$, we have

$$\frac{V_{in}}{R_{in}} = -\frac{V_{out}}{R_f}. \quad (24)$$

Moving terms around, we have

$$V_{out} = -\frac{R_f}{R_{in}} V_{in}. \quad (25)$$

Observe that the output voltage is a multiple of the input voltage with a scaling factor of $-\frac{R_f}{R_{in}}$. In addition, notice that the V_{out} and V_{in} are of opposite signs. This type of circuit is what we call an **inverting amplifier**.

More complicated op amp example

Now let's take a look at a slightly more complicated op amp circuit example with two voltage sources:

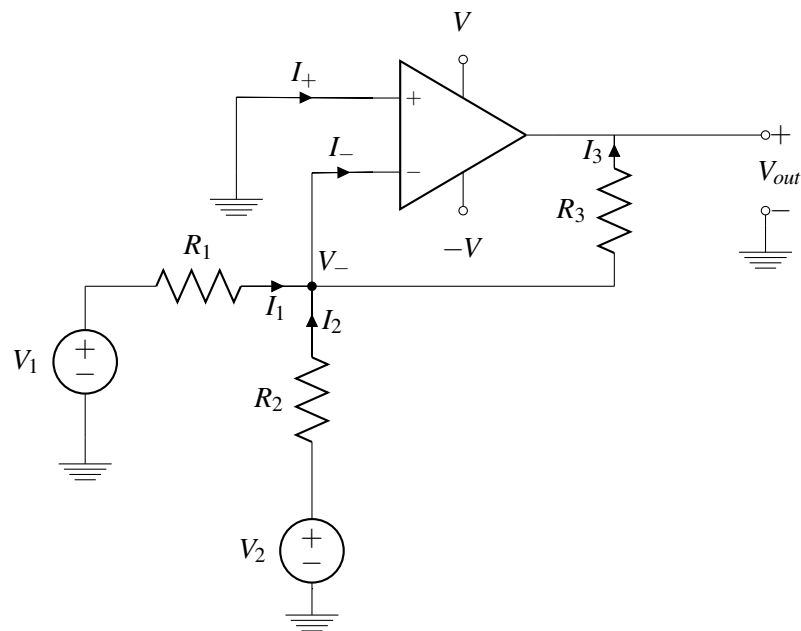

First, let's apply the first golden rule, $I_- = I_+ = 0$. Applying KCL at the node labelled V_- , we have

$$I_1 + I_2 = I_- + I_3 = 0 + I_3 = I_3. \quad (26)$$

Hence, we have

$$I_1 + I_2 = I_3. \quad (27)$$

Now by the second golden rule and the fact that the positive input terminal is connected to ground, we have

$$V_+ = V_- = 0. \quad (28)$$

Applying Ohm's law at each of the three resistors, we have

$$I_1 = \frac{V_1 - V_-}{R_1} = \frac{V_1}{R_1} \quad (29)$$

$$I_2 = \frac{V_2 - V_-}{R_2} = \frac{V_2}{R_2} \quad (30)$$

$$I_3 = \frac{V_- - V_{out}}{R_3} = -\frac{V_{out}}{R_3} \quad (31)$$

$$(32)$$

Plugging in the above result to the KCL equation $I_1 + I_2 = I_3$ derived previously, we have

$$\frac{V_1}{R_1} + \frac{V_2}{R_2} = -\frac{V_{out}}{R_3}. \quad (33)$$

Multiplying both sides by R_3 , we have

$$V_{out} = -\frac{R_3}{R_1}V_1 - \frac{R_3}{R_2}V_2, \quad (34)$$

relating the final output with the two inputs V_1 and V_2 .